

پودمان اول

کسب اطلاعات فنی





هدف از این پودمان ارتقای سطح اطلاعات فنی هنرجویان و آشنایی آنها با زبان فنی و واژه‌های کاربردی که در دیتاشیت‌ها و کتاب‌های تخصصی مرتبط با رشته مکاترونیک به کار می‌رود، بوده است. از آنجایی که بسیاری از دیتاشیت‌ها و کتب تخصصی و اطلاعات درج شده بر روی دستگاه‌ها به زبان انگلیسی می‌باشد، بنابراین زبان ارائه در این پودمان، انگلیسی است. لازم به ذکر است که در زمان یادگیری این پودمان استفاده از دیکشنری همواره آزاد است.

- روند توسعه رشته مکاترونیک چگونه بوده است؟
- استانداردهای بین المللی به چه زبانی نوشته شده اند؟
- چگونه می توان اطلاعات مورد نیاز را از یک دیتا شیت استخراج کرد؟
- کاربردهای مکاترونیک در حوزه های پزشکی، هوافضا، حمل و نقل و ... چیست؟
- اهمیت ارتینگ در دستگاه ها برای چیست؟
- چگونه می توان سیستم های کنترل بهینه ایجاد نمود؟
- چگونه می توان سیستم های الکتریکی و مکانیکی را به هم تبدیل نمود؟

این واحد یادگیری شامل روند توسعه رشته مکاترونیک، کاربردهای این رشته در علوم مختلف مانند پزشکی، حمل و نقل و هوافضا، مباحثی مفید در مورد نحوه خواندن دیتاشیت آی سی ها، پلاک موتورها، ارتینگ و در نهایت مروری بر مبحث کنترل و شبیه سازی و تبدیل سیستم ها می باشد.

در این واحد یادگیری ابتدا فایل صوتی هر متن را گوش دهید و تلفظ صحیح را یاد بگیرید. سپس به کمک کلمات ترجمه شده در کتاب همراه و کلمات کلیدی هر متن که با بیان ساده به زبان انگلیسی درون کادرهای زرد رنگ در متن مشخص شده، سعی کنید ترجمه متون را انجام دهید. در انتها از ترجمه روان و کامل استاد خود بهره بگیرید.

در درون متن فیلم هایی برای یادگیری بهتر و آشنایی بیشتر با مباحث مربوطه قرار داده شده است که باید با دیدن و گوش دادن به آنها مفهوم کلی فیلم را درک کرده و در مورد آن توضیح دهید.

بعد از درک صحیح متن و ترجمه آن به سؤالاتی که پرسیده شده پاسخ دهید. دو نوع فعالیت برای انجام دادن در نظر گرفته شده است یک نوع تمرین که با علامت و عنوان  Exercise می باشد و هنرجویان باید بعد از خواندن متن مربوط در کلاس درس به آنها پاسخ دهند و یک نوع تحقیق که با علامت و عنوان  Do a research می باشد و هنرجویان باید به عنوان تحقیق درسی برای جلسه بعدی به همراه داشته باشند.

What is Mechatronics?

Mechatronics is a natural stage in the evolutionary process of modern engineering design. The development of the computer, and then the microcomputer, embedded computers, and associated information technologies and software advances, made mechatronics an imperative in the latter part of the twentieth century. Standing at the threshold of the twenty-first century, with expected advances in integrated bioelectro-mechanical systems, quantum computers, nano and pico-systems, and other unforeseen developments, the future of mechatronics is full of potential and bright possibilities.

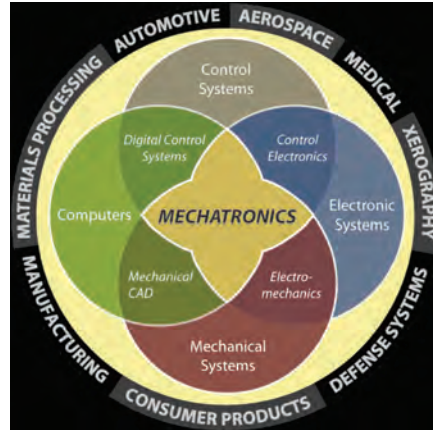

Basic Definitions:

The definition of mechatronics has evolved since the original definition by the Yasakawa Electric Company. In trademark application documents, Yasakawa defined mechatronics in this way:

The word, mechatronics, is composed of “mecha” from mechanism and the “tronics” from electronics. One of the quoted definition of mechatronics was presented in 1996 . In their words, mechatronics is defined as the synergistic integration of mechanical engineering, with electronics and intelligent computer control in the design and manufacturing of industrial products and processes.

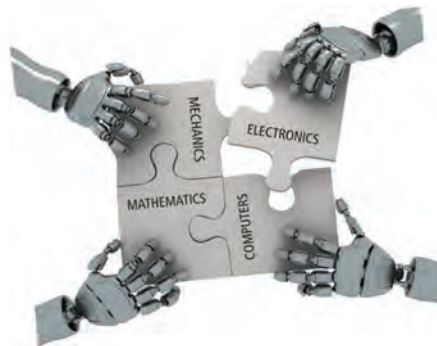

Evolutionary

relating to the way in which ideas or situations gradually change and develop over a long time

integration

the combining of two or more things so that they work together effectively

Key Elements of Mechatronics:

The study of mechatronic systems can be divided into the following areas of specialty:

1 Physical Systems Modeling

.....

2 Sensors and Actuators

.....

3 Signals and Systems

.....

4 Computers and Logic Systems

.....

5 Software and Data Acquisition

.....

Exercise



Can you give yourself a definition of mechatronic?

Acquisition

the process by which you gain knowledge or learn a skill.

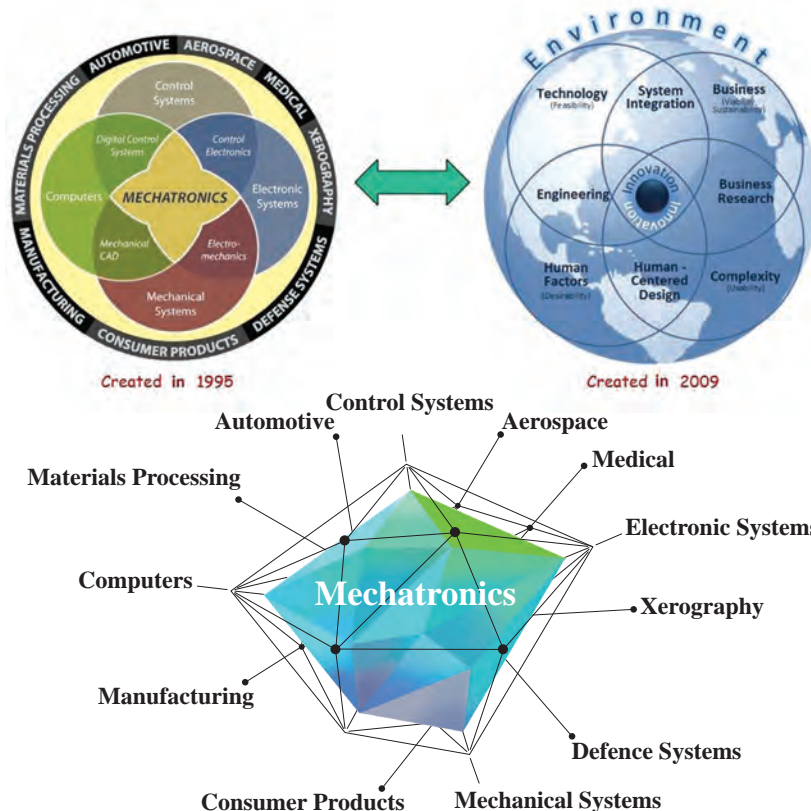

Mechatronics applications: Manufacturing Applications

CNC Bending

- Fully automated bending: load sheet metal and the finished bent parts come out
- Can bend complex shapes



- Manufacturing Applications

Micro Factory

- Desktop sized Factory
- Build small parts with a small factory
- Greatly reduces space, energy, and materials.



Micro Factory Drilling Unit



- Smart Robotics Application
BigDog



System Can

- Carry 340 lb
- Run 4 mph
- Climb, run, and walk
- Move over rough terrain

Advantages

- Robot with rough-terrain mobility that could carry equipment to remote location.

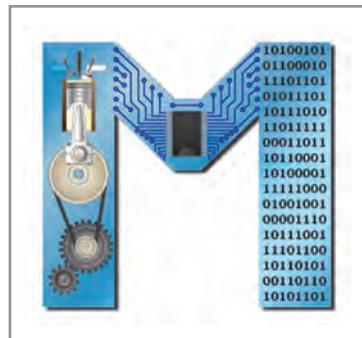

- Space Exploration Application

Phoenix Mars Lander's System Can

- Collect *specimens*
- Has automated onboard lab for testing specimens

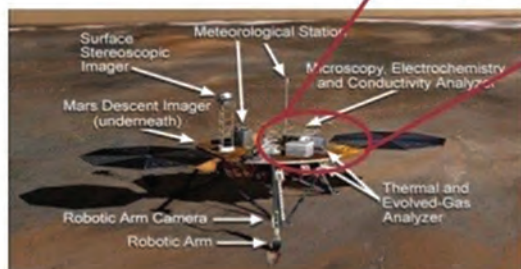

Advantages

- Robot that can travel to other planets and take measurements automatically.

- Medical Applications

- Used by Patients with slow or *erratic* heart rates. The Pacemaker will set a normal heart rate when it sees an irregular heart rhythm.

Implantable Defibrillation



Pace Maker



- Monitors the heart. If heart fibrillates or stops completely it will Shock the heart at high voltage to restore a normal heart rhythm.



- Transportation Applications

Segway System Uses

- Tilt and pressure sensors
- Microcontroller
- Motors
- Onboard power source



- Simple and intuitive Personal transportation device

- Defense



Applications

- Advanced technology is making our soldiers safer.
- Some planes can now be flown remotely.

Unmanned Aerial Vehicle



Stealth Bomber



- Sanitation Applications

System Uses

- Proximity sensors
- Control circuitry
- Electromechanical valves
- Independent power source

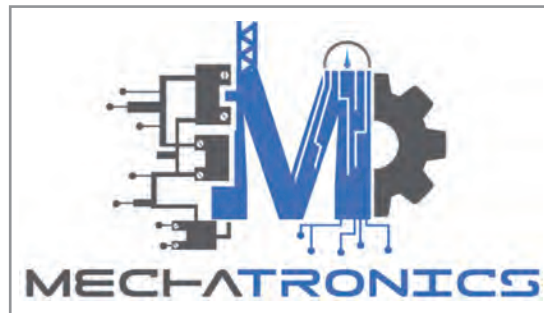
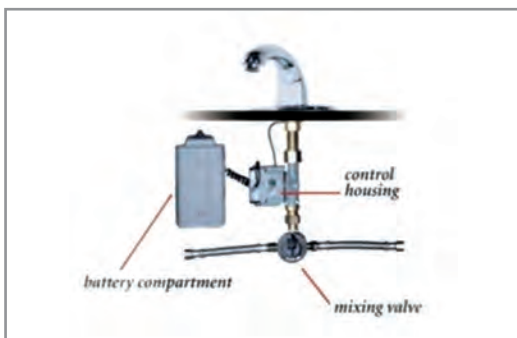

Advantages

- Reduces spread of germs by making device hands free
- Reduces wasted water by automatically turning off when not in use.

Check the logos for the mechatronics field on the pages. Each of them describes the sciences that are related to the mechatronics. What are your results when comparing the definition of mechatronics in 1995 with its definition in 2009? Mechatronics is developing along with other sciences And tries to solve more challenges.

Welcome to mechatronics.

Bend

to push or press something so that it is no longer flat or straight.



Specimen

a small amount or piece that is taken from something so that it can be tested or examined.

Erratic

something that is erratic does not follow any pattern or plan but happens in away that is not regular.

Quadcopter:

A quadcopter, also called a quadrotor helicopter or quadrotor, is a multirotor helicopter that is lifted and propelled by four rotors. Quadcopters are classified as rotorcraft, as opposed to fixed-wing aircraft, because their lift is generated by a set of rotors.



Quadcopter



Transmitter



Exercise:



Select the sample catalog as you like and answer the below questions.

1 What is it called?

.....

2 How much does it weight (Including Battery)?

.....

3 What is the Max Ascent Speed?

.....

4 What is the Max Descent Speed?

.....

5 What is the Max Speed?

.....

6 What is the Max Service Ceiling Above Sea Level?

.....

7 What is the Max Flight Time?

.....

8 What is the Operating Temperature Range?

.....

9 What is the Satellite System of the device ?

.....



See a Video about this device.

Do a research



Can you Explain the uses of this device?

Do you know what issues should be considered in making a quadcopter?

A Mechatronic system:

Antilock Braking System(ABS)

There was a time when cars were very straightforward and had regular old brakes. People who used to drive back then were trained to control cars in slippery situations and avoid locking their brakes, which would in turn cause *skidding*.

But now, with the number of cars increasing on the roads, there was a need to rethink how

brakes work and performed. With a focus on safety and control that is. This is the reason why Anti-lock Braking System (ABS) was introduced. They became more mainstream after 2012, as more and more car makers incorporated ABS in their models. If you ever wanted to know how much ABS differ from normal brakes, how it works, its advantages and disadvantages, then you've come to the right place.

Brief History of ABS:

The ABS was first introduced to the public in the early 1970s. The basic concept has remained the same as ABS has gone continuous development and innovation in the following years. One of the most prominent advancements has been the introduction of **anti-lock braking system's capability to pulse the brakes when they are applied forcefully. This basically means that your car's tires don't get jammed completely and allow you some control over your driving.** These advancements have also given birth to *Traction Control System (TCS)* and *Electronic Stability Control (ESC)*, with both of them utilizing ABS equipment for braking purposes.

Skid

a vehicle or a wheel on a vehicle skids, it suddenly slides sideways and you cannot control it.



if

ABS vs. Non-ABS (Normal Brake)

The normal brakes have very simple functionality you simply push the brake pedal so that the brake clamps would hold tightly, slow the car and eventually stop it.

However, that also increases the risk of your car sliding, since the car tires are held in a stationary position while the car has forward momentum.

This problem also will not allow the driver to steer the car and thus the likelihood of driver getting into an accident is multiplied.

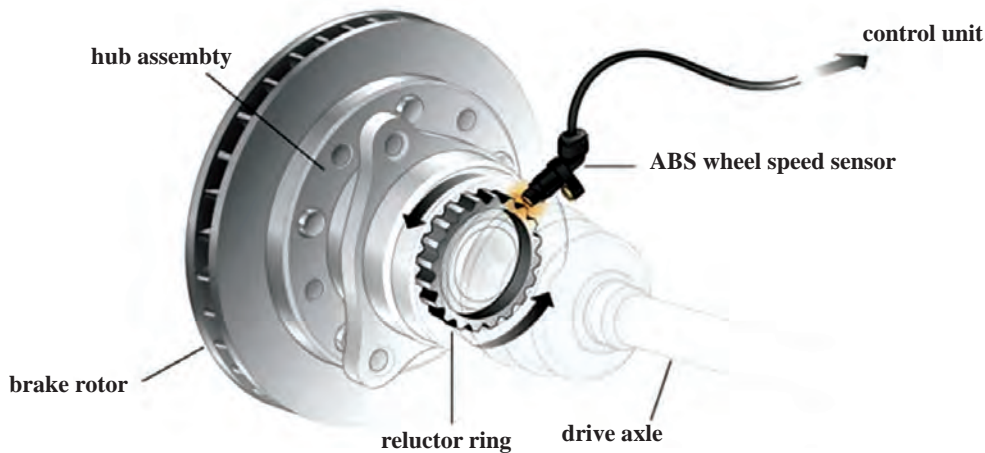

In comparison to normal brakes, ABS allow the car tires to move after small intervals even if the brakes are applied completely. Why? So the driver does not lose control of the car completely and road *grip* is maintained while the car is slowing down *simultaneously*.

grip

to hold something very tightly.



simultaneously

things that are simultaneous happen at exactly the same time.

How Does ABS Exactly Work?



To understand exactly how ABS work, see an example video:

Advantages vs. Disadvantages

- Advantages:
 - Ability to stop the car on slippery surfaces
 - Capacity to steer the car under intense breaking
 - Capability to prevent car skidding
 - Lesser stopping distance
- Disadvantages:
 - Increased expense
 - Complication with a car's electronic system
 - Inconsistent stopping distances

Since braking is one of the most important things a driver should practice often, which is why disadvantages of ABS seem minuscule at best. Nothing is worth the price of your safety and well-being so having ABS helps.

Do a research



Can you give two other applications of mechatronics in the car?
Can you identify the sensors used in the car?

Biomechatronics:

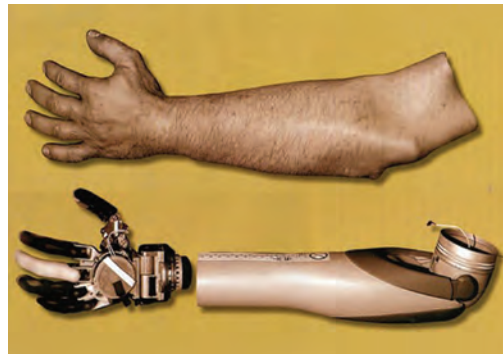

What do you know about this pictures?

In medicine, a **prosthesis** is an *artificial* extension that replaces a missing body part. It is part of the field of biomechatronics.

Biomechatronics:

An applied interdisciplinary science that integrates mechanical elements, electronics, neurosciences and parts of biological organisms.

Artificial

not real or not made of natural things but made to be like something that is real or natural.

How does It Works?

Biomechatronics devices have to be based on how the human body works. For example, four different steps must occur to be able to lift the foot to walk. First, impulses from the motor center of the brain are sent to the foot and leg muscles. Next the nerve cells in the feet send information to the brain telling it

to adjust the muscle groups or amount of force required to walk across the ground. Different amounts of force are applied depending on the type of surface being walked across. The leg's muscle spindle nerve cells then sense and send the position of the floor back up to the brain. Finally, when the foot is raised to step, signals are sent to muscles in the leg and foot to set it down.

Biosensors:

Biosensors are used to detect what the user wants to do or their intentions. In some devices the information can be relayed by the user's nervous system or muscle system. This information is related by the biosensor to a controller which can be located inside or outside the biomechatronic device.

Biomechatronic Hand:

An "ideal" artificial hand should match the requirements of prosthetics and humanoid robotics. It can be wearable by the user which means that it can be perceived as part of the natural body and should replicate sensory-motor capabilities of the natural hand. This means that the artificial hand should be felt by the user as the part of his/her own body and it should provide the user with the same functions of natural hand: tactile exploration, grasping, and manipulation.



See video No. 3

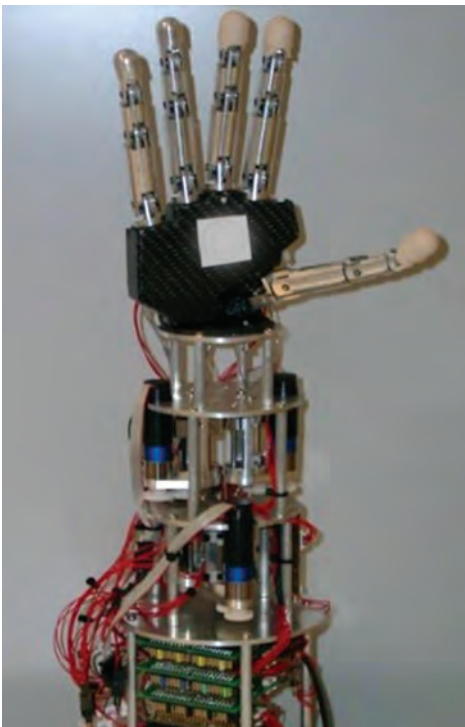

Actuator System Architecture:

In order to match the size of a human finger, two micro motors have been integrated within the palm housing and the proximal phalange of each finger.

The selected micro motors are Smoovy micro drivers (Δ mm diameter) high precision linear motion.

The main mechanical characteristics of the linear actuators are listed below.

12 N	Nominal force
20 mm/s	Maximum speed
3.2 g	Weight
40 N	Maximum load (axial)
25 N	Maximum load (radial)
1:125	Transmission rate
3	Gear stages

Think of other biomechatronic applications.

Do a research



Can you Explain the uses of this device?

Do you know what issues should be considered in making a quadcopter?

Maglev: Achievement of Mechatronics

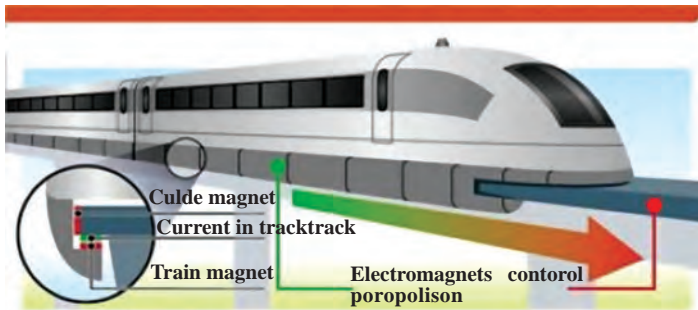

Exercise



Read the text and answer the following questions

1. What challenges do you have in creating maglev?

2. Do you know why two types of magnet are used in these trains?

3. Do you know what does different kind of magnet use for?

4. Is it true to say that the entire length of a maglev track can be considered to be part of the train's motor?

5. According to Faraday's laws When an electric current is passed through a coil of wire

6. how much is the distance between the maglev and the guide rail?

7. Do you know what causes the speed of the Maglev trains so high?

8. how much is the speed of maglev trains?

9. Express the difference between the electromagnetic suspension and the electrodynamic suspension.

10. What is the Propulsion? How are maglev trains created?

Maglev: Magnetic Levitating Trains

Maglev (derived from *magnetic levitation*) is a system of train transportation that uses two sets of magnets, one set to repel and push the train up off the track as in levitation (hence Maglev, Magnetic-levitation), then another set to move the ‘floating train’ ahead at great speed taking advantage of no friction. Within certain “medium range” locations (usually between 200-400 miles) Maglev can compete favorably with high speed rail and airplanes.

Maglev is short for Magnetic Levitation in which trains float on a guideway using the principle of magnetic repulsion. Each magnet has two poles. Now if you play with two magnets, you’ll realize that opposite poles attract, whereas similar poles repel. This repulsive property of magnets is used in Maglev trains. However instead of using permanent magnets, the principle of electromagnetism is used to create strong and large temporary magnets. When an electric current is passed through a coil of wire, magnetic field is generated around the coil according to Faraday’s laws.

Levitation

Like poles repel and PUSH the train upward

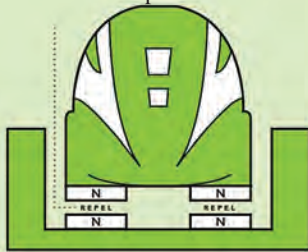

LEVITATION

Like poles repel and PUSH the train forward

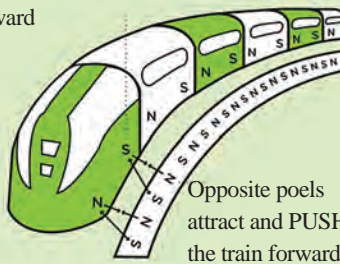

PROPULSION

Opposite poles attract and PUSH the train forward

The action of rising or causing something to rise and hover in the air, typically by means of supposed magical powers.



How Electromagnets Work

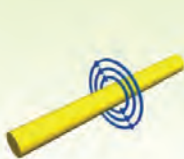

When electric current runs through a wire it generates a magnetic field around it. The magnetic field around a single wire very weak.



By winding the wire into a coil and concentrating the magnetic field it produces a stronger field. More electrical current produces a stronger magnetic field.



The magnetic field can be made even stronger by placing an iron bar in the center of the coil. This has a big effect on the electromagnets power.



Try it your self by coiling a copper wire around a nail. Then connect the wire to a 1.5V battery. See how many staples you can pick up by changing the numbers of loops. You can also see what happens if you connect it to two batteries.



A Maglev thus requires three major components:

- A large electrical power source
- Metal coils lining a guideway or track
- Large guidance magnets attached to the underside of the train

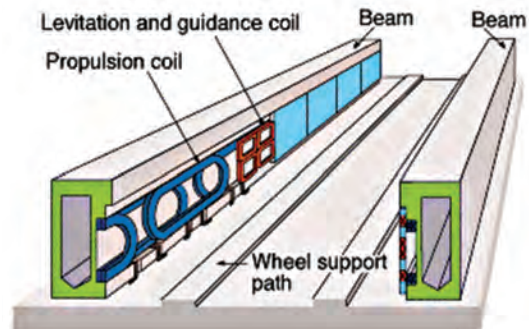

Magnetized coils run along the track called a guideway. These repel the large magnets on the train's undercarriage, allowing the train to levitate between 0.39 and 3.93 inches (1 to 10 cm) above the guideway. Once the train is levitated, power is supplied to the coils within the guideway walls to create a unique system of magnetic fields that pull and push the train along the guideway. The electric current supplied to the coils in the guideway walls is constantly alternating to change the polarity of the magnetized coils. This change in polarity causes the magnetic field in front of the train to pull the vehicle forward, while the magnetic field behind the train adds more forward thrust.

Maglev trains float on a cushion of air, eliminating friction. This lack of friction and the trains' aerodynamic designs allow these trains to reach unprecedented ground transportation speeds of more than 310 mph (500 kph).

How Does it Work?

Maglev trains do not have wheels or rails. As shown in following Figures, they have guideways, and they float down these guideways without ever touching them.

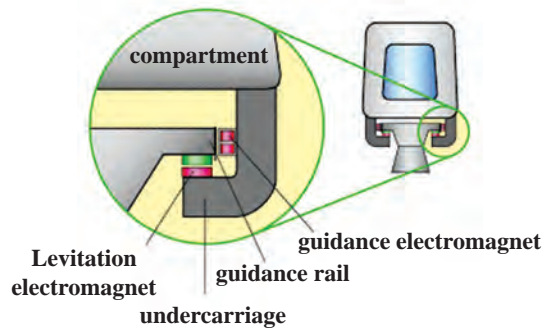
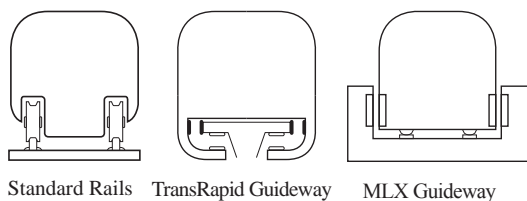

ELECTRODYNAMIC ELECTROMAGNETIC INDUCTRACK

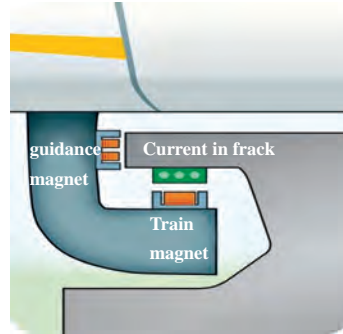
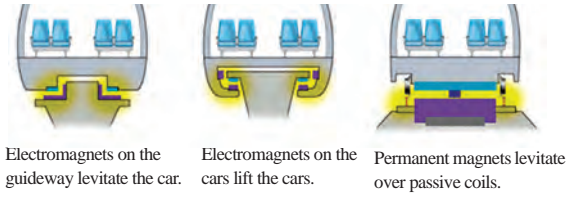

There are three essential parts to achieving maglev functionality: levitation, propulsion and guidance (as seen below).

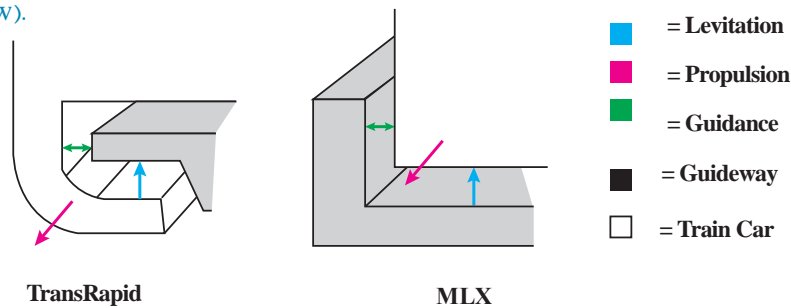

 See video No. 1

Levitation: Levitation is the ability for the train to stay suspended above the track. There are two important types of levitation technology:

Electromagnetic Suspension (EMS):

EMS (below figure) uses the attractive force of electromagnets placed on the guideway and on the train to achieve levitation. The benefits of this method are that it is simpler to implement than Electrodynamic Suspension (discussed below), and that it maintains levitation at zero speed. The drawbacks are that the system is inherently unstable. At high speeds, it becomes difficult to maintain the correct distance between train and guideway. If this distance cannot be kept, the train will fail to levitate and come grinding to a halt. To account for this, EMS requires complex feedback-control systems to ensure the train is always stable.

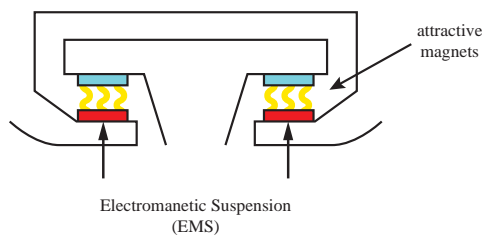

- **Electrodynamic Suspension (EDS):** EDS (below figure) uses the repulsive force of (superconducting) magnets placed on the guideway and on the train to achieve levitation. The magnets move past each other while the train is running and generate the repulsive force. The benefits of this method are that it is incredibly stable at high speeds. Maintaining correct distance between train and guideway is not a concern. The drawbacks are that sufficient speed needs to be built up in order for the train to levitate at all. Additionally, this system is much more complex and costly to implement.

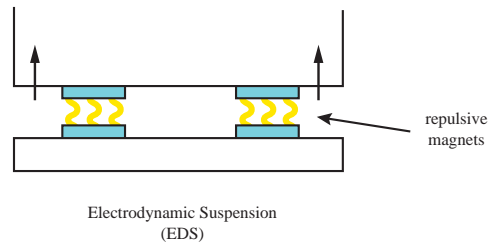

See video No. 2

Propulsion is the force that drives the train forward. Maglev uses an electric linear motor to achieve propulsion. A normal electric rotary motor uses magnetism to create torque and spin an axle. It has a stationary piece, the stator, which surrounds a rotating piece, the rotor. The stator is used to generate a rotating magnetic field. This field induces a rotational force on the rotor, which causes it to spin. A linear motor is simply an unrolled version of this (see Figure). The stator is laid flat and the rotor rests above it. Instead of a rotating magnetic field, the stator generates a field that travels down its length. Similarly, instead of a rotating force, the rotor experiences a linear force that pulls it down the stator. Thus, an electric linear motor directly produces motion in a straight line. However, this motor can only produce a force while the rotor is above the stator. Once the rotor has reached the end, it stops moving.

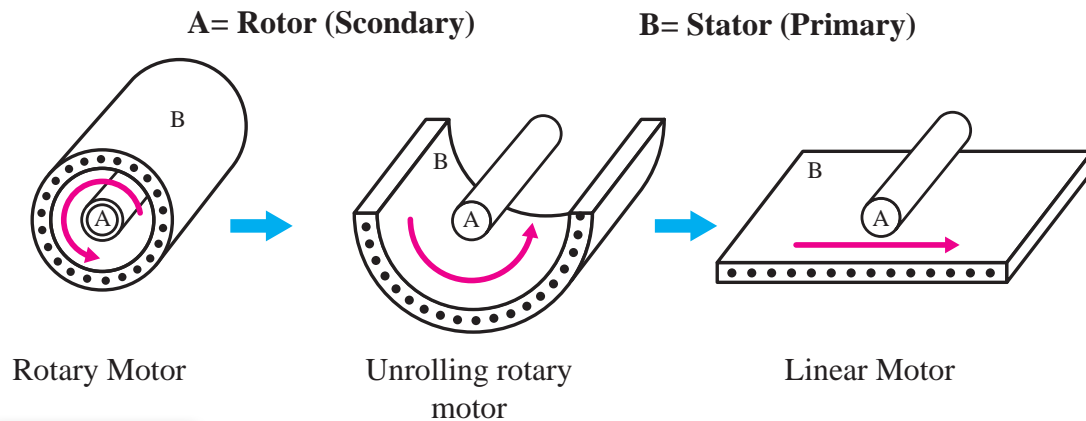

Propulsion

The action of driving or pushing forwards.

When describing a linear motor, the standard is to use the term “primary” instead of “stator,” and “secondary” instead of “rotor.” In maglev trains, the secondary is attached to the bottom of the train cars, and the primary is in the guideway. So a magnetic field is sent down the guideway and it pulls the train along after it. In a way then, the entire length of a maglev track can be considered to be part of the train’s motor. The system that has been described so far is a Linear Induction Motor (LIM).



See video No. 3

Benefits of Maglev:

The most obvious attraction of maglev trains is that they can travel faster than traditional rail trains. The only commercial high-speed maglev, the Shanghai Maglev, is now the fastest train in existence. It travels over 50 mph (80 kph) faster than the fastest high-speed wheel-rail. **The lack of friction between the train and the guideway removes many limits that bound traditional trains.** There are other, more subtle qualities that also make maglev attractive:

- **Longevity:** Conventional wheels and rails undergo a great deal of stress over time. They must be replaced and repaired periodically to remain functional. In maglev, there is no contact between train and guideway, so there is substantially less wear-and-tear. The lifespan of maglev parts are appropriately much longer due to this fact.

Economically, this is quite an incentive, as repair and maintenance are costly and time-consuming activities.

Friction:

Technical the natural force that prevents one surface from sliding easily over another surface.

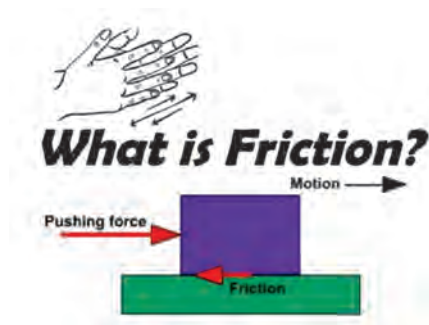

- **Safety:** It might seem counter-intuitive that these trains are safer, as they travel so much faster than their wheeled counterparts. It is true nevertheless. Maglev trains are near impossible to derail. Additionally, weather isn’t much of a problem. Since the trains don’t rely on friction for movement, snow, ice, and rain cause little to no effect.

- **Energy Efficiency:** Another benefit of levitation is that these trains don’t lose any energy to friction. This gives them an advantage in efficiency. Energy consumption is essential to the success of a transportation system. Much of the cost of operating one goes to paying for power. Therefore this is very important.

- **Noise Pollution:** When considering a transportation project, noise (within reasonable bounds) isn't as large a concern as economy or safety. However, noise reduction is still considered a positive feature. Maglev trains are quieter than contemporary trains, so this is another point in their favor.

Drawbacks of Maglev

Although there are many upsides, there are still reasons why maglev trains are not being built everywhere. Perhaps the biggest reason is that maglev guideways are not compatible with existing rail infrastructure. Any organization attempting to implement a maglev system must start from scratch and build a completely new set of tracks. This involves a very high initial investment. Even though guideways cost less than rails over time, it is hard to justify spending so much upfront. Another problem is that maglev trains travel fast, but they might not travel quite fast enough. Countries with high-speed rails already in place don't want to spend billions of dollars implementing a system that is only marginally better than the existing solution.



How to make a maglev? See video No. 4



Maglev speed racing? See video No. 5

What is earthing and why is it used?

Earthing is used to protect you from an electric shock. It does this by providing a path (a protective conductor) for a fault current to flow to earth. It also causes the protective device (either a circuit-breaker or fuse) to switch off the electric current to the circuit that has the fault.



Why earthing is required? See a video

Why is earthing necessary in electrical systems?

The earth wire creates a safe route for the current to flow through if the live wire touches the casing. **You would get an electric shock if the live wire inside an appliance, such as a cooker, came loose and touched the metal casing.**

As it's a safety factor, earthing is essential and mandatory. It's an electrical connection between the exposed metallic parts of an electrical appliance or installation and the earth, regarded to have zero potential for dangerous level of potential or voltage that endangers the user's life.

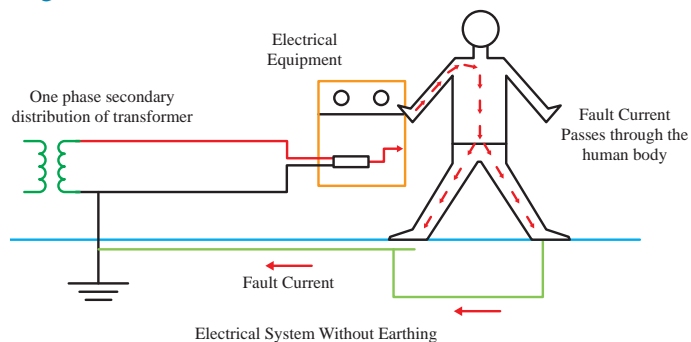

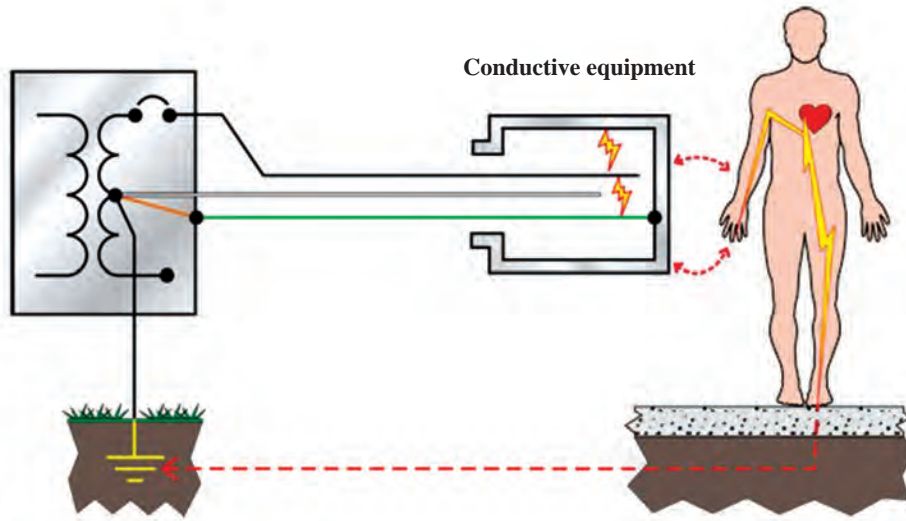

Do volts or amps kill you? See a video



Why earthing is important? See a video

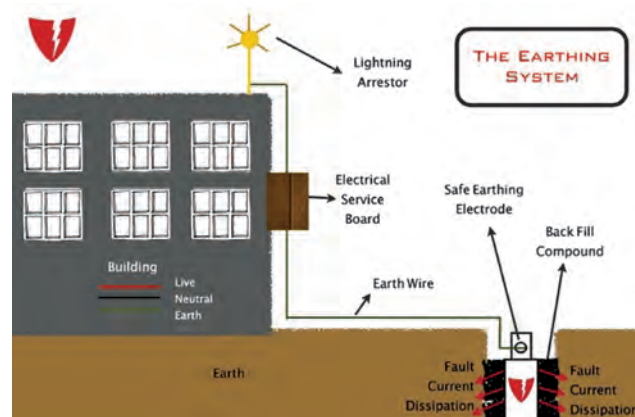

How does the earthing work?

A difference can occur when either current is flowing down the earth wire or through someone's body to ground (and back to the neutral point through the earthing system). Electricity flows only when the circuit is complete. And our body is a great conductor of Current.

What is earthing and type of earthing?

five types of earthing system: TN-S, TN-C-S, TT, TN-C, and IT.

T = Earth (from the French word Terre) N = Neutral S = Separate C = Combined I = Isolated

TN Network:

In TN type of earthing system, one of the points of the source side (Generator or Transformer) is connected to earth. This point is usually the star point in a three phase system. The body of the connected electrical device is connected to earth via this earth point on the source side. See fig

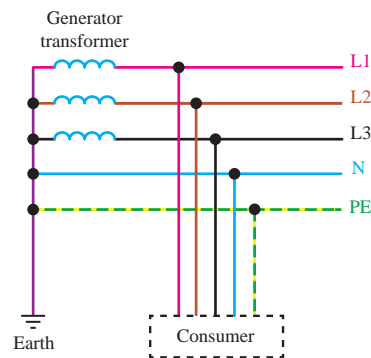

In above diagram:

PE – Acronym for “Protective Earth” – is the conductor that connects the exposed metallic parts of the consumer's electrical installation to the ground.

N –Also called Neutral. It is the conductor that connects Star point in a 3 phase system to the earth.

There are three sub-types of TN networks as below:

TN-S:

In this, separate conductors for Protective Earth (PE) and Neutral run from Consumer's electrical installation till the source. They are connected together only at the power source.

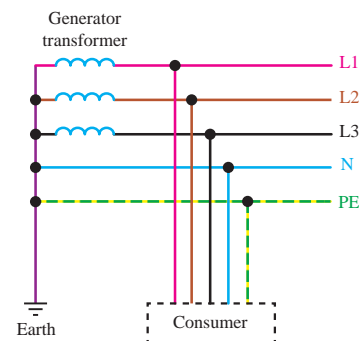

TN-C:

In this, there is a combined conductor called PEN (Protective Earth-Neutral) which is connected to earth at the source.

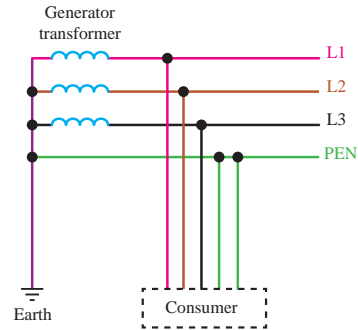

TN-C-S:

In this type of earthing, part of the system uses a combined PEN conductor for earthing, whereas for remaining part of the system uses separate conductor for PE and N. Usually, the combined PEN conductor is used near the source of the system.

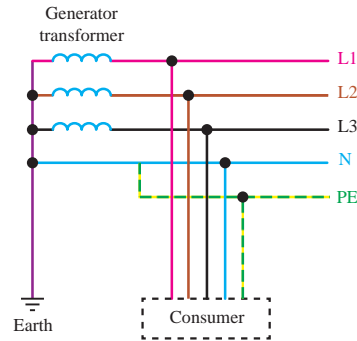

TT Network:

In TT type of earthing system, consumer employs its own local earth connection in the premises, which is independent of any earth connection at source side. This type of earthing is preferred in telecommunication applications, because this system is free of any high or low frequency noise that comes through neutral wire connected to the equipment.

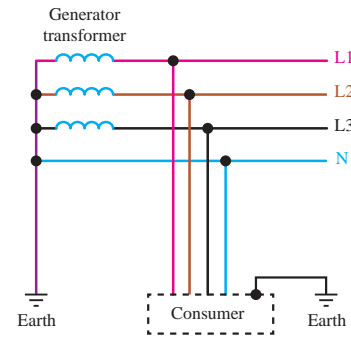

IT Network:

In IT type of earthing system, there is either no connection to earth at all, or it is done via a high impedance earthing connection.

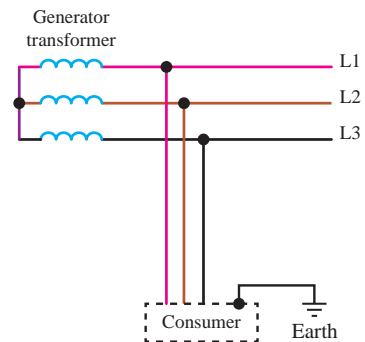

resistance of earths :

In TN or TT systems, the total earthing resistance of all functional earths should be as low as possible to limit the voltage rise against earth of all other conductors, particularly the protection or PEN conductor in the TN network if an earth fault occurs on a phase.

A value of 2Ω is considered sufficient in TN systems. If the value of 2Ω cannot be reached in soils of low conductivity, the following condition must be met:

$$\frac{R_B}{R_E} \leq \frac{50V}{U_0 - 50V}$$

R_B total earthing resistance of all parallel earths of the system

R_E assumed lowest earth resistance of conductive parts not connected to a protective conductor over which an earth fault can occur.

U_0 rated voltage (r.m.s) against earth.

What are earthing system types ?

Different types of earthing systems are available. Popular methods are:

- **Plate Earthing:** A copper plate or galvanized plate is buried in an earth pit below ground level. The plate electrode connects the electrical conductors to the earth.
- **Pipe Earthing:** A galvanized steel perforated pipe inside the ground connects the electrical conductors to the earth.
- **Rod Earthing:** Similar to the Pipe earthing. A copper rod replaces the pipe electrode.



See an interesting video about earthing.

Do a research



How is an earth system implemented?

Which type of earthing is used in residential homes in iran?

Do you know how much should be the resistance of the earth system?

Why earth resistance in the earthing system should be less than 2 ohms?

Understanding motor's nameplate

Motor nameplate is normally located on all produced electric motors. Understanding nameplate information can be hard sometimes, but is essential. In most countries it is a requirement for manufacturers to display all information on the motor's nameplate, but often this is not the case. However, when a motor has been **in operation for a long time**, it is often not possible to determine its operating information because nameplates of motors are often lost or painted over.

Electrical input:

1. Voltage

This data tells you **at which voltage the motor is made to operate**. Nameplate-defined parameters for the motor such as power factor, efficiency, torque and current are at rated voltage and frequency. When the motor is used at other voltages than the voltage indicated on the nameplate, its performance will be affected.

3-MOT MG 90SA2-24FF165-C2		P ₂ 1,50 kW No85807906	
50 Hz	U 220-240D/380-415Y V		
Eff. %	I _{1n} 5.90/3.40	A	
82	I _{max} 6.50/3.75	A	
n 2860-2890	min	cos φ 0.85-0.79	
CL F	IP 55	0346	
DE 6305.2Z.C4 NDE 6205.2Z.C3			
EFF 2		GRUNDFOS	

2. Frequency

Usually for motors, the input **frequency is 50 or 60 Hz**. If more than one frequency is marked on the nameplate, then other parameters that will differ at different input frequencies have to be indicated on the nameplate as well.

GRUNDFOS		EFF I		CE	
Type MMG160L2-42FF300D IEC 60034 3~Mot No 300296030001 H					
Th CL F(R) IP55 86kg TP111 Made by AEG					
50Hz: Δ/Y		8,5kW 380-415/660-690V 34,5/19,9A			
60Hz: Δ/Y		8,5kW 380-480/660-690V			
2930 min ⁻¹ cos φ 0,87					
60Hz: 27.6-34.5/19.9A 3530-3560/min 0.9-0.89pf P/N 81615728					
Bearing DE/NDE:7309B/62092Z Grease: UNIREX N3 ESSO					
Protector type PTC 160°C, Release temperature 155°C, Ready temperature 145°C					
After 4000h 9 ccm grease 0106					

3. Phase

This parameter represents **the number of AC power lines** that supply the motor. Single-phase and three-phase are considered as the standard.

3-MOT MG 90SA2-24FF165-C2		P ₂ 1,50 kW No85807906	
50 Hz	U 220-240D/380-415Y V		
Eff. %	I _{1n} 5.90/3.40	A	
82	I _{max} 6.50/3.75	A	
n 2860-2890	min	cos φ 0.85-0.79	
CL F	IP 55	0346	
DE 6305.2Z.C4 NDE 6205.2Z.C3			
EFF 2		GRUNDFOS	

4. Current

Current indicated on the nameplate corresponds to the **rated power output together with voltage and frequency**. Current may deviate from the nameplate amperes if the phases are unbalanced or if the voltage turns out to be lower than indicated.

3-MOT MG 90SA2-24FF165-C2		P ₂ 1,50 kW No85807906	
50 Hz	U 220-240D/380-415Y V		
Eff. %	I _{1n} 5.90/3.40	A	
82	I _{max} 6.50/3.75	A	
n 2860-2890	min	cos φ 0.85-0.79	
CL F	IP 55	0346	
DE 6305.2Z.C4 NDE 6205.2Z.C3			
EFF 2		GRUNDFOS	

5. Type

Some manufacturers use type to define the motor as single-phase or poly-phase, single-phase or multi-speed or by type of construction. **Nevertheless, there are no industry standards for type.**

3-MOT	MG 90SA2-24FF165-C2	
50 Hz	P ₂ 1.50 kW No85807906	
	U 220-240D/380-415Y V	
Eff. %	I _{1/1} 5.90/3.40	A
82	I _{max} 6.50/3.75	A
n 2860-2890	min	cos φ 0.85-0.79
CL F	IP 55	0346
DE 6305.2Z.C4	NDE 6205.2Z.C3	
EFF 2		
CE GRUNDFOS		

6. Power factor

Power factor is indicated on the nameplate as either “PF” or “P.F” or $\cos \phi$. Power factor is an expression of the ratio of active power (W) to apparent power (VA) expressed as a percentage.

3-MOT	MG 90SA2-24FF165-C2	
50 Hz	P ₂ 1.50 kW No85807906	
	U 220-240D/380-415Y V	
Eff. %	I _{1/1} 5.90/3.40	A
82	I _{max} 6.50/3.75	A
n 2860-2890	min	cos φ 0.85-0.79
CL F	IP 55	0346
DE 6305.2Z.C4	NDE 6205.2Z.C3	
EFF 2		
CE GRUNDFOS		

Mechanical Input:

7. kW or horsepower

kW or horsepower (HP) is an expression of the motor’s mechanical output rating that is its ability to deliver the torque needed for the load at rated speed.

8. Full-load speed

Full-load speed is the speed at which rated full-load torque is delivered at rated power output. **Normally, the full-load speed is given in RPM.** This speed is sometimes called slip-speed or actual rotor speed.

Performance:

9. Efficiency

Efficiency is the motor’s output power divided by its input power multiplied by 100. **Efficiency is expressed as a percentage.** Efficiency is guaranteed by the manufacturer to be within a certain tolerance band, which varies depending on the design standard, eg IEC or NEMA.

Therefore, pay attention to **guaranteed minimum efficiencies**, when you evaluate the motor’s performance.

Efficiency label		
Full-load speed		
Efficiency in percent		
kW		
3-MOT	MG 90SA2-24FF165-C2	
50 Hz	P ₂ 1.50 kW No85807906	
	U 220-240D/380-415Y V	
Eff. %	I _{1/1} 5.90/3.40	A
82	I _{max} 6.50/3.75	A
n 2860-2890	min	cos φ 0.85-0.79
CL F	IP 55	0346
DE 6305.2Z.C4	NDE 6205.2Z.C3	
EFF 2		
CE GRUNDFOS		

10. Duty

This parameter defines the length of time during which the motor can carry its nameplate rating safely. In many cases, the motor can do it continuously, which is indicated by an **S1** or “**Cont**” on the nameplate. If nothing is indicated on the nameplate, the motor is designed for duty cycle S1.

Reliability:

11. Insulation class

Insulation class (INSUL CLASS) is an expression of the standard classification of the thermal tolerance of the motor winding. Insulation class is a letter designation such as “**B**” or “**F**”, depending on the winding’s ability to survive a given operating temperature for a given life. The farther in the alphabet, the better the performance.

For instance, a class “**F**” insulation has a longer nominal life at a given operating temperature than a class “**B**”.

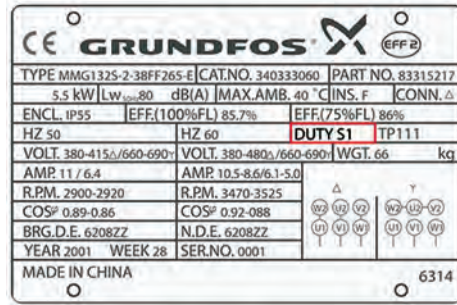

12. Maximum ambient temperature

The maximum ambient temperature at which a motor can operate is **sometimes indicated on the nameplate**. If not the maximum is **40°C for EFF2 motors** and normally **60°C for EFF1 motors**. The motor can run and still be within the tolerance of the insulation class at the maximum rated temperature.

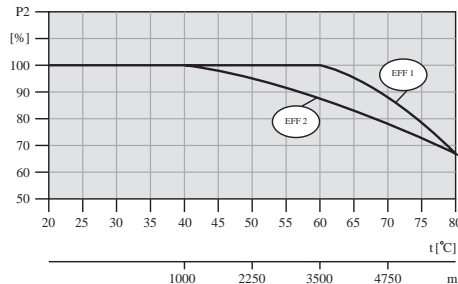

13. Altitude

This indication shows **the maximum height above sea level** at which the motor will remain within its design temperature rise, meeting all other nameplate data.

Construction:

14. Enclosure

Enclosure classifies a motor as to its degree of protection from its environment and its method of cooling. Enclosure is shown as **IP** or **ENCL** on the nameplate.

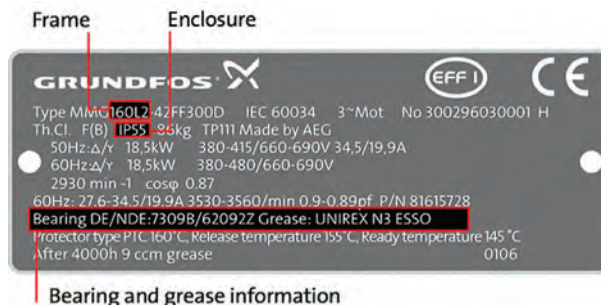

15. Frame

The frame size data on the nameplate is an important piece of information. It determines mounting dimensions such as the **foot hole mounting pattern** and the **shaft height**. The frame size is often a part of the type designation which can be difficult to interpret because special shaft or mounting configurations are used.

16. Bearings

Bearings are the component in an AC motor **that requires the most maintenance**. The information is usually given for both the **drive-end (DE) bearing** and the bearing opposite the drive-end, **non drive-end (NDE)**.

NEMA

Besides the above mentioned information, **NEMA nameplates have some supplementary information**.

The most important ones are:

Letter code.

Design letter.

Service factor.

17. Letter code

A letter code defines the **locked rotor current kVA on a per horsepower basis**. The letter code consists of letters from A to V. The farther away from the letter code A, the higher the inrush current per horsepower.

NEMA code letter	Locked rotor KVA/HP	NEMA code letter	Locked rotor KVA/HP
A	0 -3.15	L	9.0 -10.0
B	3.15 -3.55	M	10.0 -11.2
C	3.55 -4.0	N	11.2 -12.5
D	4.0 -4.5	O	NOT USED
E	4.5 -5.0	P	12.5 -14.0
F	5.0 -5.6	Q	NOT USED
G	5.6 -6.3	R	14.0 -16.0
H	6.3 -7.1	S	16.0 -18.0
I	NOT USED	T	18.0 -20.0
J	7.1 - 8.0	U	20.0 -22.4
K	8.0 -9.0	V	22.4 AND UP

18. Design letter

Design letter covers the characteristics of torque and current of the motor. **Design letter (A, B, C or D)** defines the different categories. Most motors are **design A** or **B** motors.

A design A motor torque characteristic is similar to the characteristic of a design B motor; but there is no limit in starting inrush current.

So, when replacing a motor in an application, **it is important to check the design letter**, because some manufacturers assign their products with letters that are not considered industry standard which may lead to starting problems.

19. Service factor

A motor designed to operate at its nameplate power rating has a **service factor of 1.0**. This means that the motor can operate at **100% of its rated power**.

Some applications require **a motor that can exceed the rated power**. In these cases, a motor with a service factor of 1.15 can be applied to the rated power. A 1.15 service factor motor can be operated at 15% higher than the motor's nameplate power.

However, any motor that operates continuously at a service factor that exceeds 1 will have reduced life expectancy compared to operating it at its rated power.



How to read a motor nameplate?

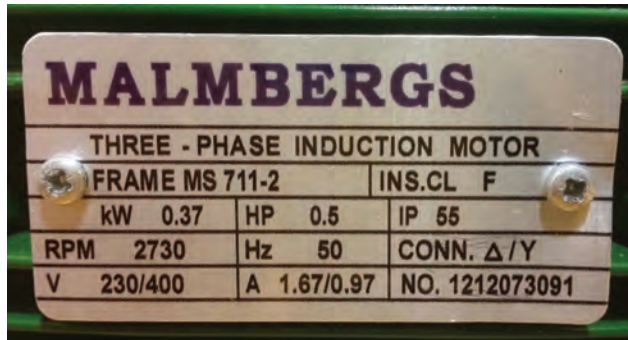

Exercise



The above image shows the actual motor's nameplate. Answer the following questions according to the photo.

1. what is the voltage of the motor?
2. what is the input frequency of the motor?
3. Is it a three phase or single phase?
4. What is the power of the motor? (kw and hp)
5. What is the speed of the motor in full load?
6. What is the degree of protection for this motor?

How to read a datasheet?

Datasheets are instruction manuals for electronic components. They (hopefully) explain exactly what a component does and how to use it. Unfortunately these documents are usually written by engineers for other engineers, and as such they can often be difficult to read, especially for newcomers. Nevertheless, datasheets are still the best place to find the details you need to design a circuit or get one working.

A datasheet's contents will vary widely depending on the type of part, but they will usually have most of the following sections:

The first page is usually a **summary** of the part's function and features. This is where you can quickly find a description of the part's functionality, the basic **specifications** (numbers that describe what a part needs and can do), and sometimes a **functional block diagram** that shows the internal functions of the part. This page will often give you a good first impression as to whether potential part will work for your project or not:



3-Axis, $\pm 2\text{ g}/\pm 4\text{ g}/\pm 8\text{ g}/\pm 16\text{ g}$ Digital Accelerometer

ADXL345

FEATURES

- Ultralow power: as low as 40 μA in measurement mode and 0.1 μA in standby mode at $V_S = 2.5\text{ V}$ (typical)
- Power consumption scales automatically with bandwidth
- User-selectable resolution
 - Fixed 10-bit resolution
 - Full resolution, where resolution increases with g range, up to 13-bit resolution at $\pm 16\text{ g}$ (maintaining 4 mg/LSB scale factor in all g ranges)
- Embedded, patent pending FIFO technology minimizes host processor load
- Tap/double tap detection
- Activity/inactivity monitoring
- Free-fall detection
- Supply voltage range: 2.0 V to 3.6 V
- I/O voltage range: 1.7 V to V_S
- SPI (3- and 4-wire) and I²C digital interfaces
- Flexible interrupt modes mappable to either interrupt pin
- Measurement ranges selectable via serial command
- Bandwidth selectable via serial command
- Wide temperature range (-40°C to $+85^\circ\text{C}$)
- 10,000 g shock survival
- Pb free/RoHS compliant
- Small and thin: 3 mm \times 5 mm \times 1 mm LGA package

APPLICATIONS

- Handsets
- Medical instrumentation
- Gaming and pointing devices
- Industrial instrumentation
- Personal navigation devices
- Hard disk drive (HDD) protection
- Fitness equipment

GENERAL DESCRIPTION

The ADXL345 is a small, thin, low power, 3-axis accelerometer with high resolution (13-bit) measurement at up to $\pm 16\text{ g}$. Digital output data is formatted as 16-bit twos complement and is accessible through either a SPI (3- or 4-wire) or I²C digital interface.

The ADXL345 is well suited for mobile device applications. It measures the static acceleration of gravity in tilt-sensing applications, as well as dynamic acceleration resulting from motion or shock. Its high resolution (4 mg/LSB) enables measurement of inclination changes less than 1.0° .

Several special sensing functions are provided. Activity and inactivity sensing detect the presence or lack of motion and if the acceleration on any axis exceeds a user-set level. Tap sensing detects single and double taps. Free-fall sensing detects if the device is falling. These functions can be mapped to one of two interrupt output pins. An integrated, patent pending 32-level first in, first out (FIFO) buffer can be used to store data to minimize host processor intervention.

Low power modes enable intelligent motion-based power management with threshold sensing and active acceleration measurement at extremely low power dissipation.

The ADXL345 is supplied in a small, thin, 3 mm \times 5 mm \times 1 mm, 14-lead, plastic package.

FUNCTIONAL BLOCK DIAGRAM

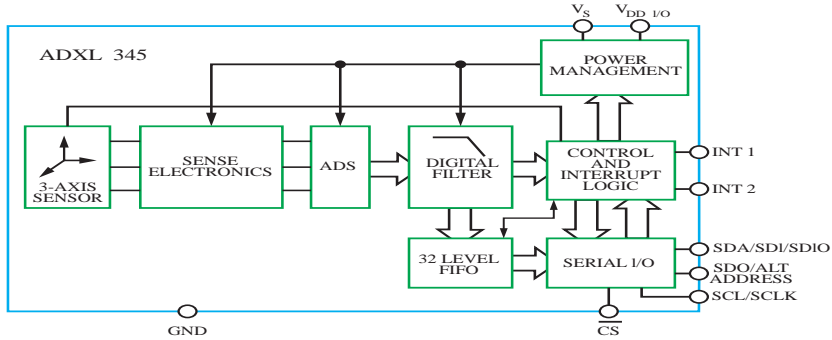

A **pinout** lists the part's pins, their functions, and where they're physically located on the part for various packages the part might be available in. Note the special marks on the part for determining where pin 1 is (this is important when you plug the part into your circuit!), and how the pins are numbered (the below parts are numbered counterclockwise). You'll find some acronyms here: VCC is the supply voltage (commonly 5V or 3.3V), CLK is clock, CLR is clear, OE is output enable, etc. If a pin has a star next to it or a line over the name, that's an indication that the pin is active low which means that you'll pull the pin low (0V) to activate it, rather than H (VCC):

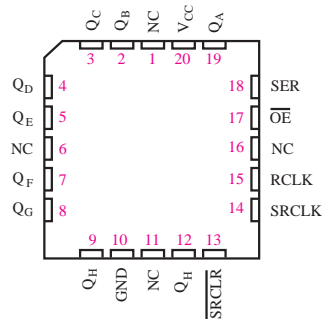
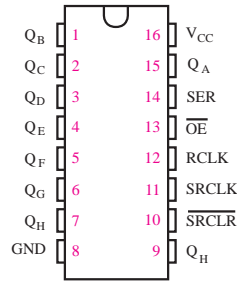

Detailed tables of electrical specifications follow. These will often list the **absolute maximum ratings** a part can withstand before being damaged. Never exceed these

ABSOLUTE MAXIMUM RATINGS

Parameter	Rating
Acceleration	
Any Axis, Unpowered	10,000 g
Any Axis, Powered	10,000 g
V _S	-0.3 V to +3.6 V
V _{DD I/O}	-0.3 V to +3.6 V
Digital Pins	-0.3 V to V _{DD I/O} + 0.3 V or 3.6 V, whichever is less
All Other Pins	-0.3 V to +3.6 V
Output Short-Circuit Duration (Any Pin to Ground)	Indefinite
Temperature Range	
Powered	-40°C to +105°C
Storage	-40°C to +105°C

You'll also see the more normal **recommended operating conditions**. These may include voltage and current ranges for various functions, timing information, temperature ranges, bus addresses, and other useful performance information.

7.3 Recommended Operating Conditions

over operating free-air temperature range (unless otherwise noted)⁽¹⁾

		SN54HC595			SN74HC595			UNIT
		MIN	NOM	MAX	MIN	NOM	MAX	
V_{CC}	Supply voltage	2	5	6	2	5	6	V
V_{IH}	High-level input voltage	$V_{CC} = 2\text{ V}$		1.5	1.5		V	
		$V_{CC} = 4.5\text{ V}$		3.15	3.15			
		$V_{CC} = 6\text{ V}$		4.2	4.2			
V_{IL}	Low-level input voltage	$V_{CC} = 2\text{ V}$		0.5		0.5	V	
		$V_{CC} = 4.5\text{ V}$		1.35		1.35		
		$V_{CC} = 6\text{ V}$		1.8		1.8		
V_I	Input voltage	0	V_{CC}		0	V_{CC}		V
V_O	Output voltage	0	V_{CC}		0	V_{CC}		V
$\Delta t/\Delta v$	Input transition rise or fall time ⁽²⁾	$V_{CC} = 2\text{ V}$		1000		1000		ns
		$V_{CC} = 4.5\text{ V}$		500		500		
		$V_{CC} = 6\text{ V}$		400		400		
T_A	Operating free-air temperature	-55		125	-40		85	°C

- (1) All unused inputs of the device must be held at V_{CC} or GND to ensure proper device operation. See the TI application report, *Implications of Slow or Floating CMOS Inputs*, SCBA004.
- (2) If this device is used in the threshold region (from $V_{IL\text{ max}} = 0.5\text{ V}$ to $V_{IH\text{ min}} = 1.5\text{ V}$), there is a potential to go into the wrong state from induced grounding, causing double clocking. Operating with the inputs at $t_i = 1000\text{ ns}$ and $V_{CC} = 2\text{ V}$ does not damage the device; however, functionally, the CLK inputs are not ensured while in the shift, count, or toggle operating modes.

Some parts will have one or more **graphs** showing the part's performance vs. various criteria (supply voltage, temperature, etc.) Typical Performance characteristics.

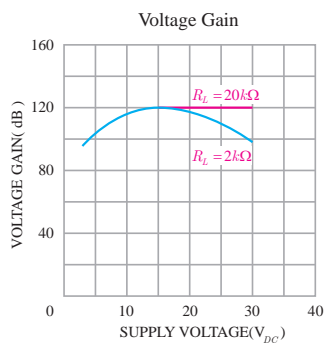
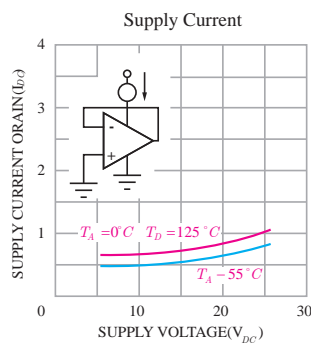
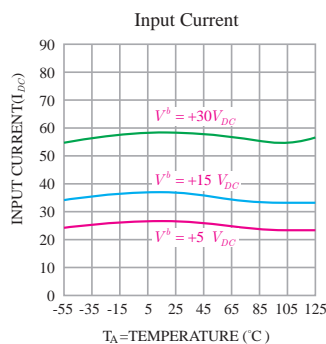
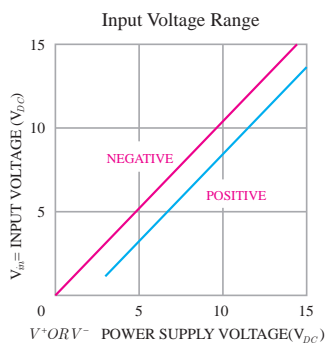

tables show how changing the inputs to a part will affect its output. “H” means that input is a logical high (usually VCC), “L” means a logical low (usually GND), “X” means the chip doesn’t care what the input is (could be H or L), and an arrow means that you should change the state of that pin from L to H or H to L depending on the arrow direction. This is called “clocking” an input, and many chips rely on this for proper operation:

SN54HC595, SN74HC595
8-BIT SHIFT REGISTERS
WITH 3-STATE OUTPUT REGISTERS
9CLO0412 - DECEMBER 1992 - REVISED FEBRUARY 2004

FUNCTION TABLE

INPUTS					FUNCTION
SER	SRCLK	SRCLR	RCLK	OE	
X	X	X	X	H	Outputs Q _A -Q _H are disabled.
X	X	X	X	L	Outputs Q _A -Q _H are enabled.
X	X	L	X	X	Shift register is cleared.
L	↑	H	X	X	First stage of the shift register goes low. Other stages store the data of previous stage, respectively.
H	↑	H	X	X	First stage of the shift register goes high. Other stages store the data of previous stage, respectively.
X	X	X	↑	X	Shift-register data is stored in the storage register.

Timing diagrams show how data should be sent to and received from the part, and what speed it should be sent / received. These are typically laid out with various inputs and outputs as horizontal lines, showing the logic transitions that happen to those lines over time.

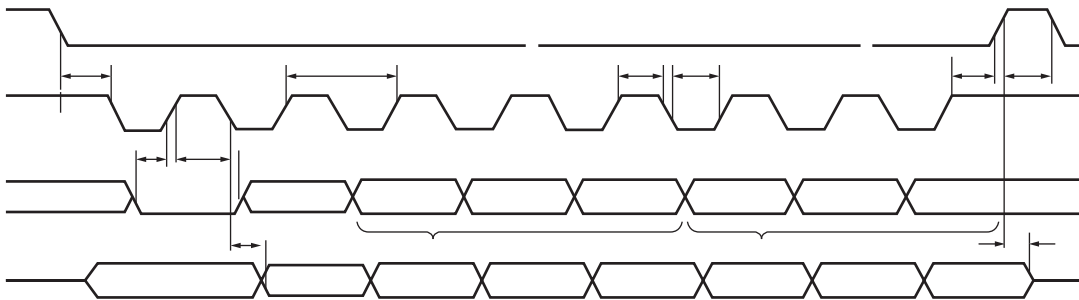

Complex parts will have extensive **application information**. This varies depending on the part, but may include detailed descriptions of pin functions, how to communicate with the part, lists of commands, memory tables, etc. This is often very useful information, so read through it carefully:

ADXL345

I²C

With \overline{CS} tied high to V_{DDIO} , the ADXL345 is in I²C mode, requiring a simple 2-wire connection as shown in Figure 8. The ADXL345 conforms to the *UM10204 I²C-Bus Specification and User Manual*, Rev. 03—19 June 2007, available from NXP Semiconductor. It supports standard (100 kHz) and fast (400 kHz) data transfer modes if the timing parameters given in Table 11 and Figure 10 are met. Single- or multiple-byte reads/writes are supported, as shown in Figure 9. With the SDO/ALT ADDRESS pin high, the 7-bit I²C address for the device is 0x1D, followed by the R/W bit. This translates to 0x3A for a write and 0x3B for a read. An alternate I²C address of 0x53 (followed by the R/W bit) can be chosen by grounding the SDO/ALT ADDRESS pin (Pin 12). This translates to 0xA6 for a write and 0xA7 for a read.

If other devices are connected to the same I²C bus, the nominal operating voltage level of these other devices cannot exceed V_{DDIO} by more than 0.3 V. External pull-up resistors, R_p , are necessary for proper I²C operation. Refer to the *UM10204 I²C-Bus Specification and User Manual*, Rev. 03—19 June 2007, when selecting pull-up resistor values to ensure proper operation.

Table 10. I²C Digital Input/Output Voltage

Parameter	Limit ¹	Unit
Digital Input Voltage		
Low Level Input Voltage (V_{IL})	$0.25 \times V_{DDIO}$	V max
High Level Input Voltage (V_{IH})	$0.75 \times V_{DDIO}$	V min
Digital Output Voltage		
Low Level Output Voltage (V_{OL}) ²	$0.2 \times V_{DDIO}$	V max

¹ Limits based on characterization results; not production tested.
² The limit given is only for $V_{DDIO} < 2$ V. When $V_{DDIO} > 2$ V, the limit is 0.4 V max.

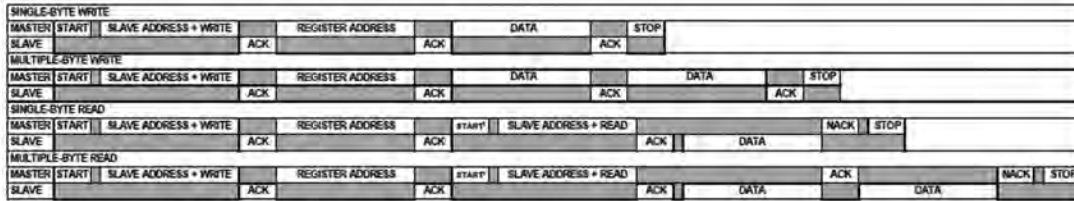
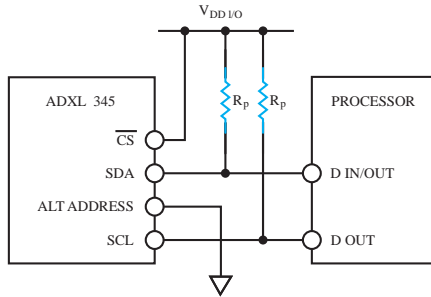

[†]THIS START IS EITHER A RESTART OR A STOP FOLLOWED BY A START.

NOTES
 1. THE SHADED AREAS REPRESENT WHEN THE DEVICE IS LISTENING.

PC Device Addressing

Some datasheets will include **example schematics** for various circuits that can be built around the part. These are often very useful building blocks for interesting projects, so be sure to look through them:

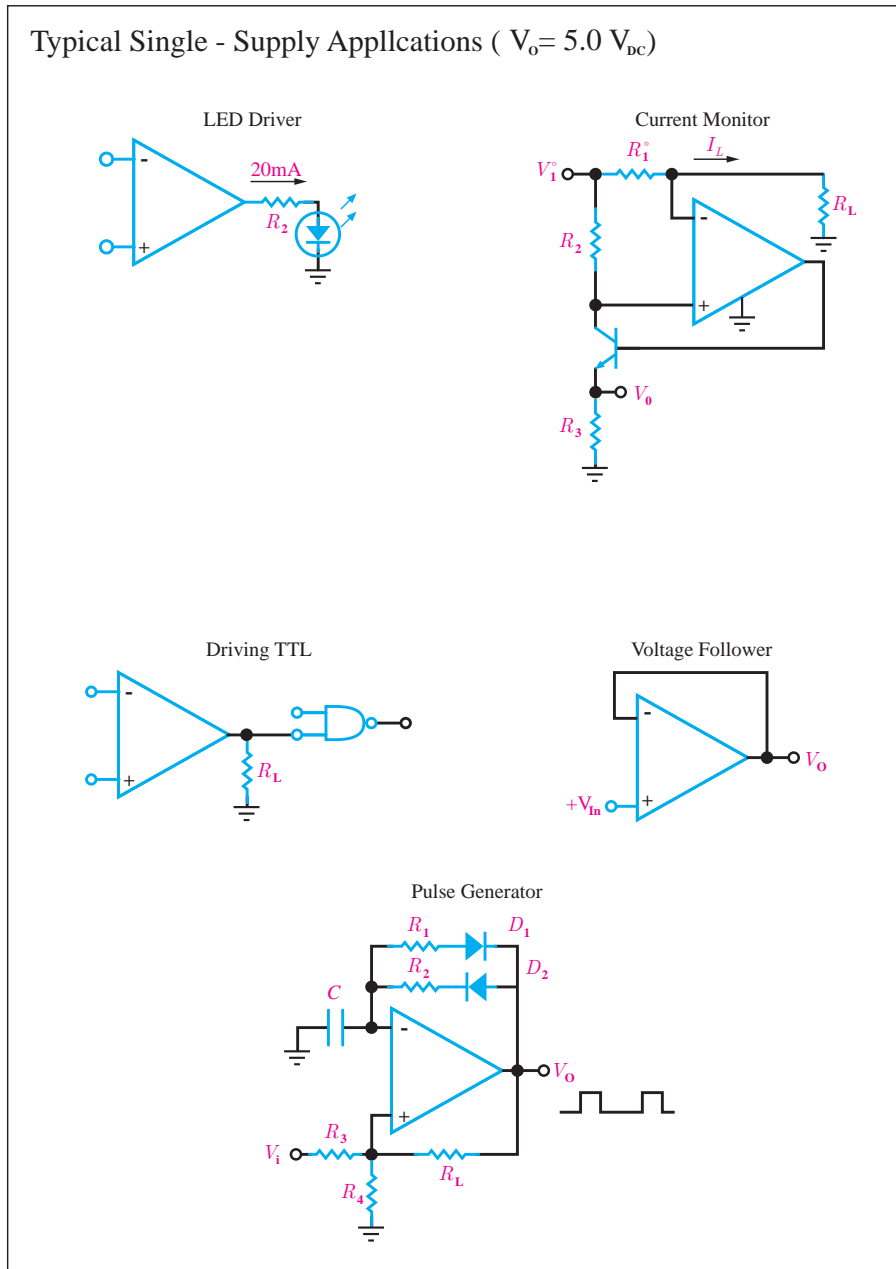

Some parts are sensitive to the way they're built into a circuit, and the datasheet will provide **layout considerations**. These can range from noise-reduction techniques, to dealing with thermal issues, to mechanical mounting considerations as with the accelerometer follow.

MECHANICAL CONSIDERATIONS FOR MOUNTING

The ADXL345 should be mounted on the PCB in a location close to a hard mounting point of the PCB to the case. Mounting the ADXL345 at an unsupported PCB location, as shown in Figure 12, may result in large, apparent measurement errors due to undamped PCB vibration. Locating the accelerometer near a hard mounting point ensures that any PCB vibration at the accelerometer is above the accelerometer's mechanical sensor resonant frequency and, therefore, effectively invisible to the accelerometer.

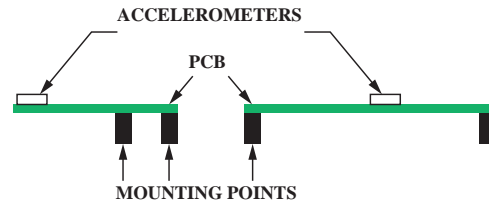
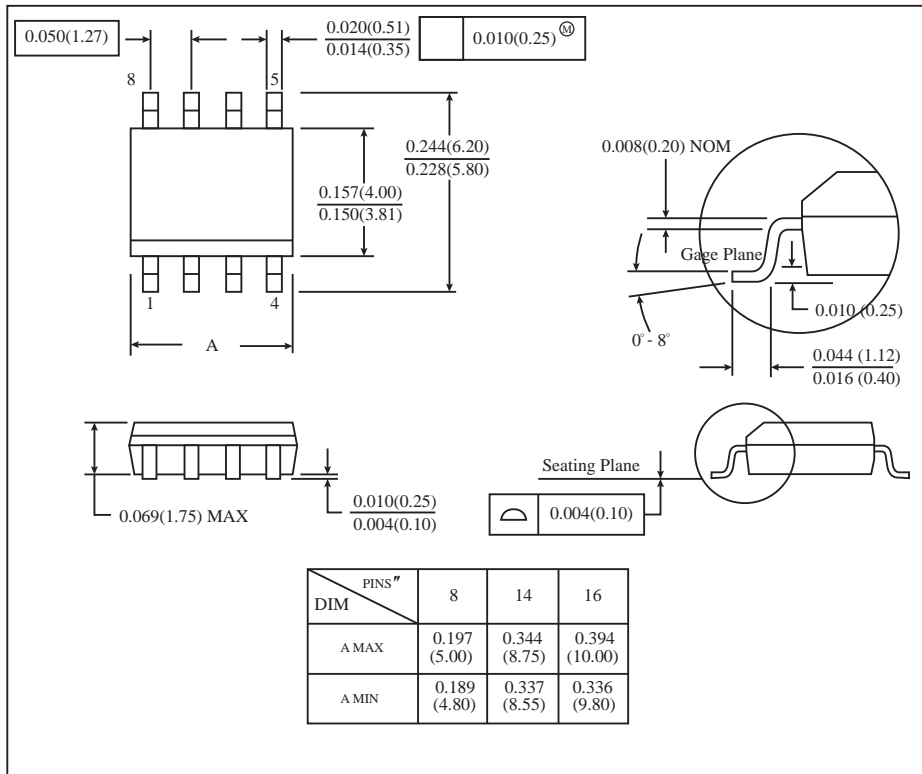

Figure 12. Incorrectly placed Accelerometers

At the end of many datasheets is **packaging information**, which provides accurate dimensions of the packages a part is available in. This is very useful for PCB layout.



Finally, a few of users have correctly pointed out that datasheets are subject to having errors just like anything else. To reduce this possibility, be sure you have the latest version of a datasheet before doing any serious work.

When working with a new part for the first time, or when deciding which part to use for your project, it's a very good idea to read that part's datasheet from beginning to end.

A datasheet is the best place to find:

- A. What voltage a part needs to run
- B. How fast a part will run
- C. How to communicate with a part
- D. All of the above

The correct answer is D: all of the above. Pretty much any technical information you need to know about a part should be somewhere in the datasheet.

Exercise:



Read the Data Sheet IC 74LS00

Extract the information below.

What is the power supply voltage?

What is the operating temperature range?

What kind of gate is?

Draw the function table.

How long is its propagation delay time?

Control systems:

Now, we describe a general process for designing a control system. A control system consisting of interconnected components is designed to achieve a desired purpose. To understand the purpose of a control system, it is useful to examine examples of control systems through the course of history. These early systems incorporated many of the same ideas of feedback that are in use today.

Modern control engineering practice includes the use of control design strategies for improving manufacturing processes, the efficiency of energy use, and advanced automobile control (including rapid transit, among others). We will examine these very interesting applications of control engineering and introduce the subject area of mechatronics.

a component or process to be controlled can be represented by a block, as shown in Figure 1.1. The input-output relationship represents the cause-and-effect relationship of the process, which in turn represents a processing of the input signal to provide an output signal variable, often with a power amplification. An open-loop control system utilizes a controller or control actuator to obtain the desired response, as shown in Figure 1.2. An open-loop system is a system without feedback.

An open-loop control system utilizes an actuating device to control the process directly without using feedback

FIGURE 1.1
Process to be controlled.



FIGURE 1.2
Open-loop control system (without feedback).



FIGURE 1.3
Closed-loop feedback control system (with feedback).

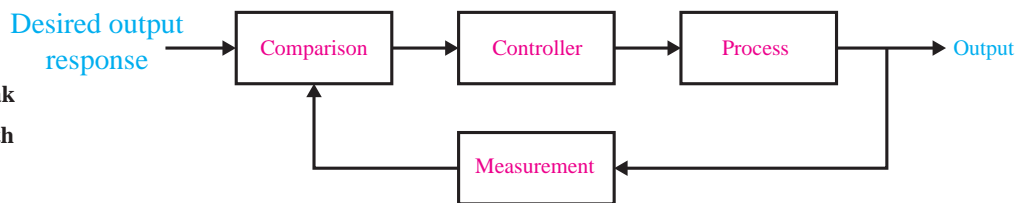

In contrast to an open-loop control system, a closed-loop control system utilizes an additional measure of the actual output to compare the actual output with the desired output response. The measure of the output is called the feedback signal. A simple closed-loop feedback control system is shown in Figure 1.3. A feedback control system is a control system that tends to maintain a prescribed relationship of one system variable to another by comparing functions of these variables and using the difference as a means of control.

A feedback control system often uses a function of a prescribed relationship between the output and reference input to control the process. Often the difference between the output of the process under control and the reference input is amplified and used to control the process so that the difference is continually reduced. The feedback concept has been the foundation for control system analysis and design.

A closed-loop control system uses a measurement of the output and feedback of this signal to compare it with the desired output (reference or command).

Closed-loop control system : Flush toilet

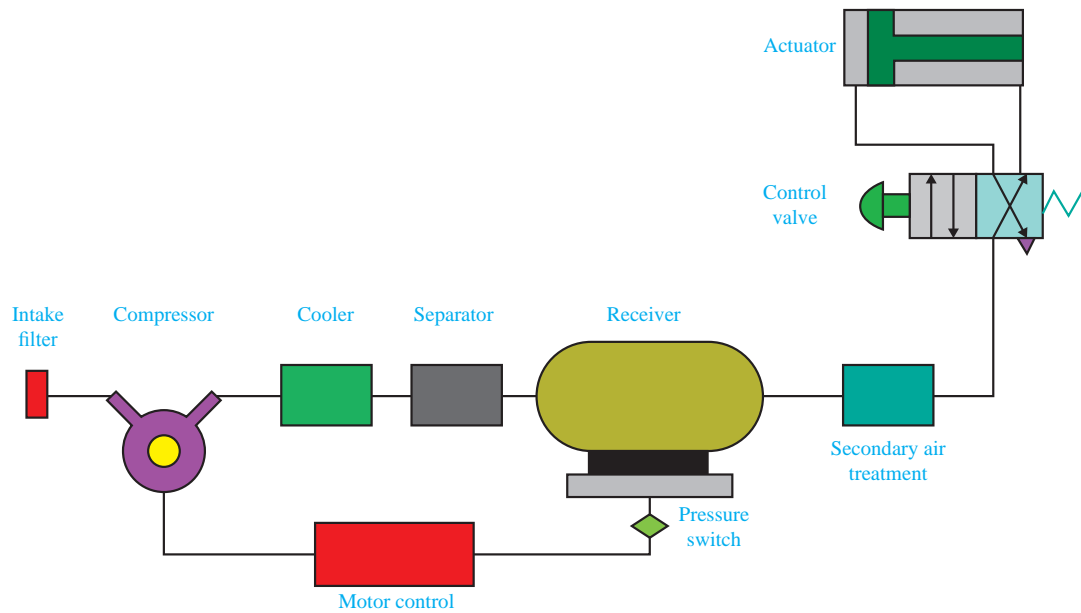
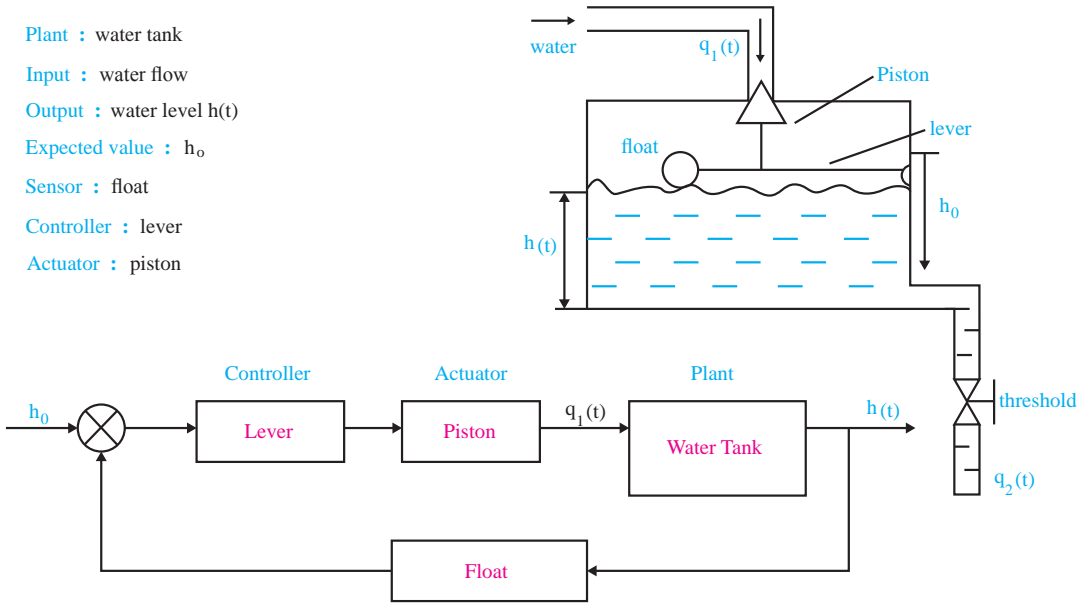

Closed-loop control system : Pneumatic jack

HISTORY OF AUTOMATIC CONTROL:

The first automatic feedback controller used in an industrial process is generally agreed to be James Watt's flyball governor, developed in 1769 for controlling the speed of a steam engine. The all-mechanical device, shown in Figure 1.4, measured the speed of the output shaft and utilized the movement of the flyball with speed to control the valve and therefore the amount of steam entering the engine. As the speed increases, the ball weights rise and move away from the shaft axis, thus closing the valve. The flyweights require power from the engine to turn and therefore cause the speed measurement to be less accurate.

The first historical feedback system, claimed by Russia, is the water-level float regulator. The level regulator system is shown in Figure 1.5. The float detects the water level and controls the valve that covers the water inlet in the boiler.

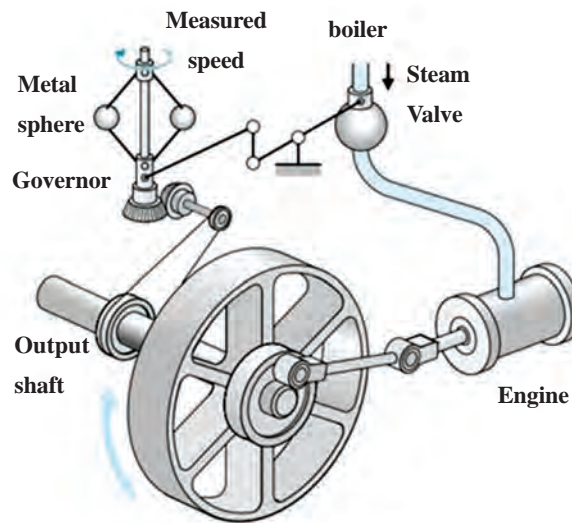

FIGURE 1.4
Watt's flyball governor.



See a clip about flyball governor

Section 1.2 History of Automatic Control

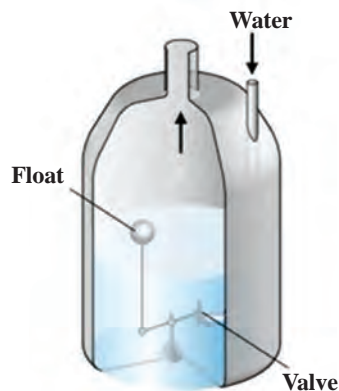

FIGURE 1.5
Water-level float regulator.

EXAMPLES OF MODERN CONTROL SYSTEMS:

1. automobile steering control system

Feedback control is a fundamental fact of modern industry and society. Driving an automobile is a pleasant task when the auto responds rapidly to the driver's commands. Many cars have power steering and brakes, which utilize hydraulic amplifiers for amplification of the force to the brakes or the steering wheel. A simple block diagram of an automobile steering control system is shown in Figure 1.6(a). The desired course is compared with a measurement of the actual course in order to generate a measure of the error, as shown in Figure 1.6(b). This measurement is obtained by visual and tactile (body movement) feedback. There is an additional feedback from the feel of the steering wheel by the hand (sensor). This feedback system is a familiar version of the steering control system in an ocean liner or the flight controls in a large airplane.

Control systems operate in a closed-loop sequence, as shown in Figure 1.7. With an accurate sensor, the measured output is equal to the actual output of the system. The difference between the desired output and the actual output is equal to the error, which is then adjusted by the control device (such as an amplifier). The output of the control device causes the actuator to modulate the process in order to reduce the error. The sequence is such, for instance, that if a ship is heading incorrectly,

Chapter1 Introduction to Control Systems

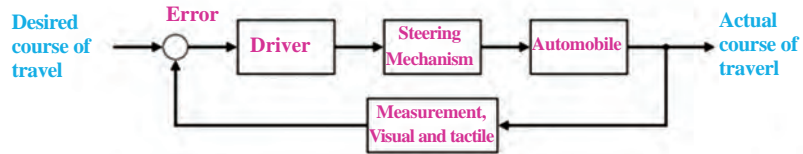

FIGURE 1.6
 (a) Automobile steering control system. (b) The driver uses the difference between the actual and the desired direction of travel to generate a controlled adjustment of the steering wheel.

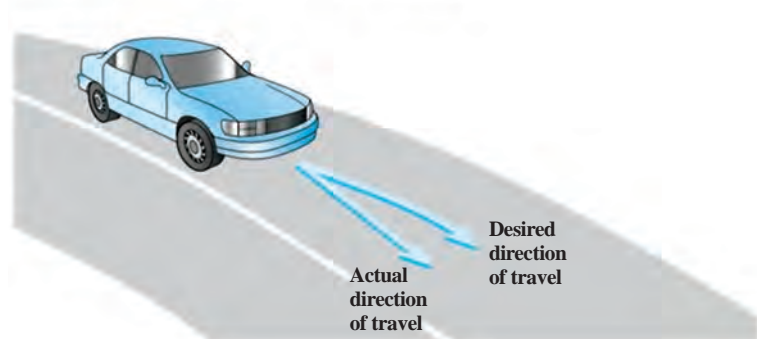
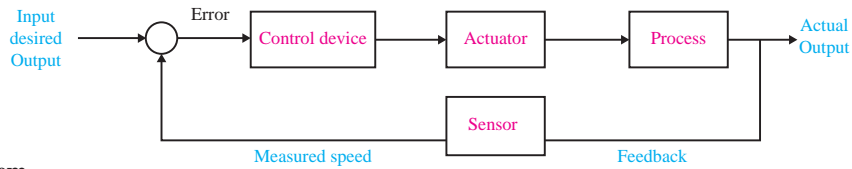

FIGURE 1.7

A negative feedback system block diagram depicting a basic closed-loop control system.

The control device is often called a “controller.”



to the right, the rudder is actuated to direct the ship to the left. The system shown in Figure 1.7 is a negative feedback control system, because the output is subtracted from the input and the difference is used as the input signal to the power amplifier.

Another very important application of control technology is in the control of the modern automobile. Control systems for suspension, steering, and engine control have been introduced. Many new autos have a four-wheel-steering system, as well as an antiskid control system.

Do a research



Can the automatic control system be able to identify traffic signs?
What do you know about image processing?

2. three-axis control system

A three-axis control system for inspecting individual semiconductor wafers is shown in Figure 1.8. This system uses a specific motor to drive each axis to the desired position in the x-y-z-axis, respectively. The goal is to achieve smooth, accurate movement in each axis. This control system is an important one for the semiconductor manufacturing industry.

FIGURE 1.8

A three-axis control system for inspecting individual semiconductor wafers with a highly sensitive camera.

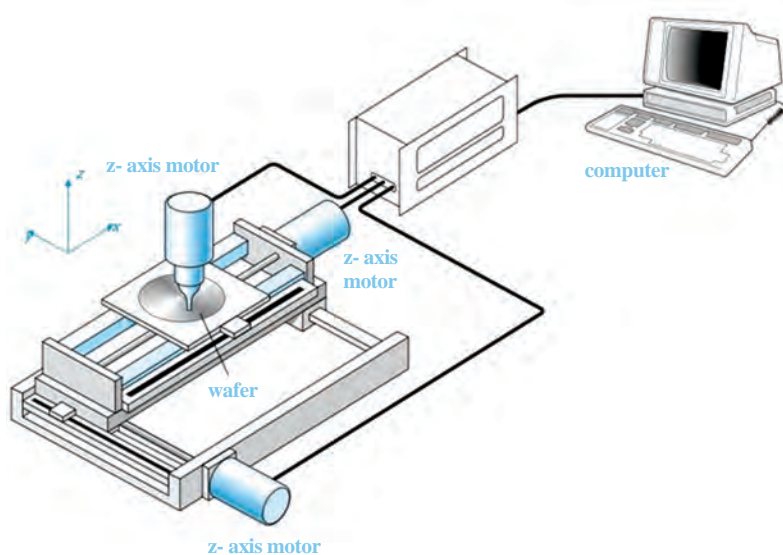

3. Dextrous robotic hand

there have been many applications of control system theory to biomedical experimentation, diagnosis, prosthetics, and biological control systems. The control systems under consideration range from the cellular level to the central nervous system and include temperature regulation and neurological, respiratory, and cardiovascular control. Most physiological control systems are closed-loop systems.

An artificial hand that uses force feedback signals and is controlled by the amputee's bioelectric control signals, which are called electromyographic signals, is shown in Figure 1.9.

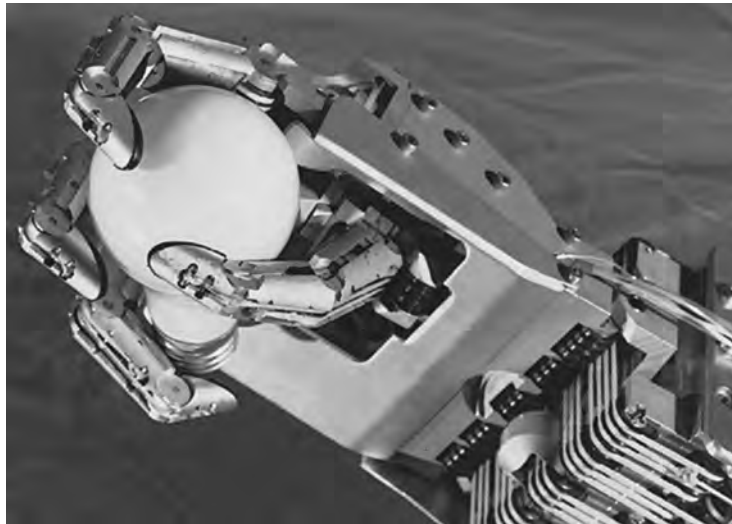

FIGURE 1.9
The Utah/MIT Dextrous Robotic Hand: A dextrous robotic hand having 18 degrees of freedom

CONTROL SYSTEM DESIGN

The design of control systems is a specific example of engineering design. Again, the goal of control engineering design is to obtain the configuration, specifications, and identification of the key parameters of a proposed system to meet an actual need.

Exercise:



To summarize control system design process in Figure 1.10.
Complete the left diagram with the right phrases

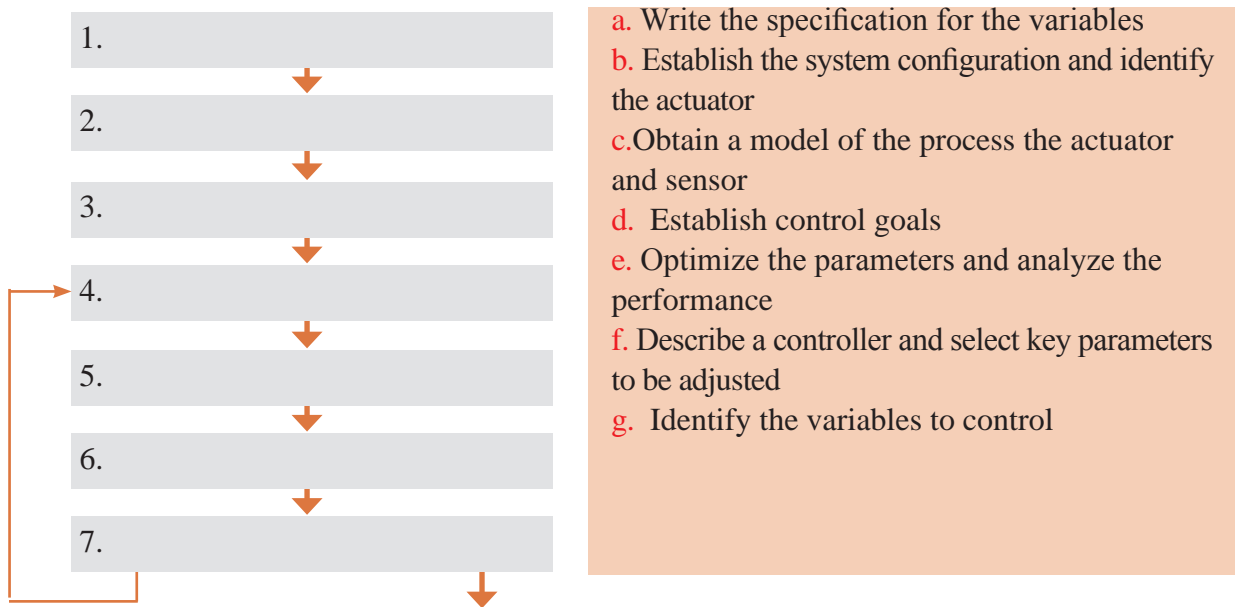

- a. Write the specification for the variables
- b. Establish the system configuration and identify the actuator
- c. Obtain a model of the process the actuator and sensor
- d. Establish control goals
- e. Optimize the parameters and analyze the performance
- f. Describe a controller and select key parameters to be adjusted
- g. Identify the variables to control

If the performance does not meet the specifications then iterate the configuration and the actuator

If the performance meets the specifications then finalize the design

FIGURE 1.10

The control system design process

In summary, the controller design problem is as follows: Given a model of the system to be controlled (including its sensors and actuators) and a set of design goals, find a suitable controller, or determine that none exists.

DESIGN EXAMPLE:

TURNTABLE SPEED CONTROL

Many modern devices use a *turntable* to rotate a disk at a constant speed. For example, a CD player, a computer disk drive, and a phonograph record player all require a constant speed of rotation in spite of motor wear and variation and other component changes. Our goal is to design a system for turntable speed control that will ensure that the actual speed of rotation is within a specified percentage of the desired speed. We will consider a system without feedback and a system with feedback.

FIGURE 1.11

(a) Open-loop
(without feedback)
control of the speed of a turntable.
(b) Block diagram model

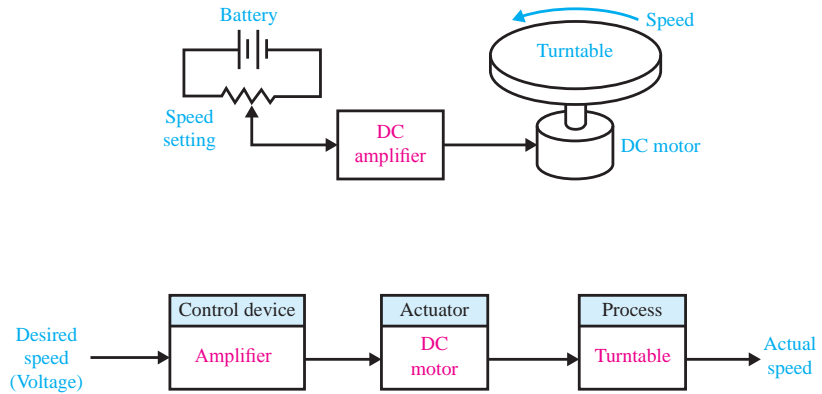

To obtain disk rotation, we will select a DC motor as the actuator because it provides a speed proportional to the applied motor voltage. For the input voltage to the motor, we will select an amplifier that can provide the required power.

The open-loop system (without feedback) is shown in Figure 1.11(a). This system uses a battery source to provide a voltage that is proportional to the desired speed. This voltage is amplified and applied to the motor. The block diagram of the open-loop system identifying control device, actuator, and process is shown in Figure 1.11(b).

To obtain a feedback system with the general form of Fig. 1.7, we need to select a sensor. One useful sensor is a *tachometer* that provides an output voltage proportional to the speed of its shaft. Thus the closed-loop feedback system takes the form shown in Fig. 1.12(a). The block diagram model of the feedback system is shown in Fig. 1.12(b). The error voltage is generated by the difference between the input voltage and the tachometer voltage.

FIGURE 1.12

(a) Closed-loop
control of the speed
of a turntable.
(b) Block diagram
model

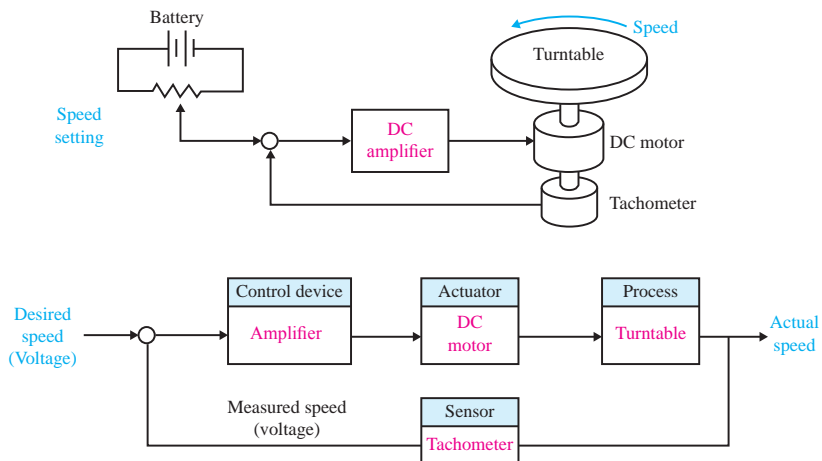

We expect the feedback system of Figure 1.12 to be superior to the open-loop system of Figure 1.11 because the feedback system will respond to errors and work to reduce them. With precision components, we could expect to reduce the error of the feedback system to one-hundredth of the error of the open-loop system.

Turntable:

A large flat round surface on which railway engines are turned around.

Tachometer:

An instrument which measures the working speed of an engine (especially in a road vehicle), typically in revolutions per minute.



[See a video about Tachometer.](#)

DESIGN EXAMPLE: INSULIN DELIVERY CONTROL SYSTEM:

we develop a preliminary design plan by carrying out steps 1 through 4 of the design control systems. Thus, for this example, we will

- 1 establish the control goal.
- 2 identify the variables to control
- 3 write the pre-liminary specifications.
- 4 establish one or more possible system configurations.

Control systems have been utilized in the biomedical field to create implanted automatic drug-delivery systems to patients. Automatic systems can be used to regulate blood pressure, blood sugar level, and heart rate. A common application of control engineering is in the field of open-loop system drug delivery, in which mathematical models of the dose-effect relationship of the drugs are used. A drug-delivery system implanted in the body uses an open-loop system, since miniaturized glucose sensors are not yet available. The best solutions rely on individually programmable, pocket-sized insulin pumps that can deliver insulin according to a preset time history. More complicated systems will use closed-loop control for the measured blood glucose levels. Our goal (step 1) is to design a system to regulate the blood sugar concentration of a diabetic. The blood glucose and insulin concentrations for a healthy person are shown in Figure 1.13. The system must provide the insulin from a reservoir implanted within the diabetic person. Thus, the variable we wish to control (step 2) is the blood glucose concentration. The specification for the control system (step 3) is to provide a blood glucose level for the diabetic that closely approximates (tracks) the glucose level of a healthy person (Figure 1.13). In step 4, we propose

a preliminary system configuration. An open-loop system would use a preprogrammed signal generator and miniature motor pump to regulate the insulin delivery rate as shown in Figure 1.14(a). The feedback control system would use a sensor to measure the actual glucose level and compare that level with the desired level, thus turning the motor pump on when it is required, as shown in Figure 1.14(b).

FIGURE 1.13
The blood glucose and insulin levels

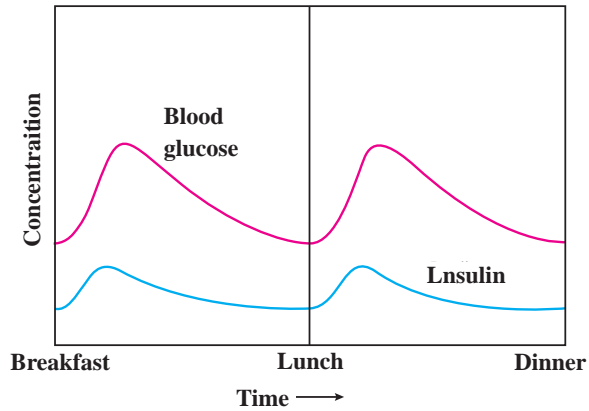
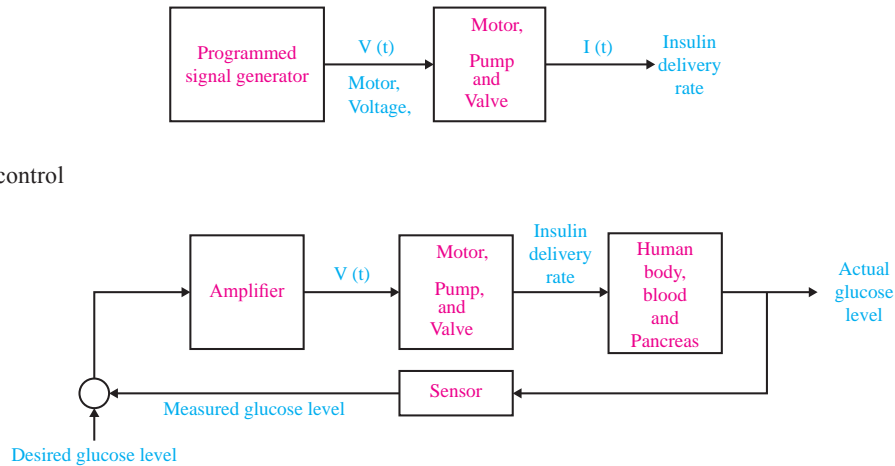

FIGURE 1.14
(a) Open-loop control (without feedback) and
(b) closed-loop control of blood glucose.



Exercise:



Design a close loop control system to regulate heart rate.

Exercise:



Read the following text carefully

Try to design a control system for the process

A light-seeking control system, used to track the sun, is shown in Figure 1.15. The output shaft, driven by the motor through a worm reduction gear, has a bracket attached on which are mounted two photo-cells. Complete the closed-loop system so that the system follows the light source.

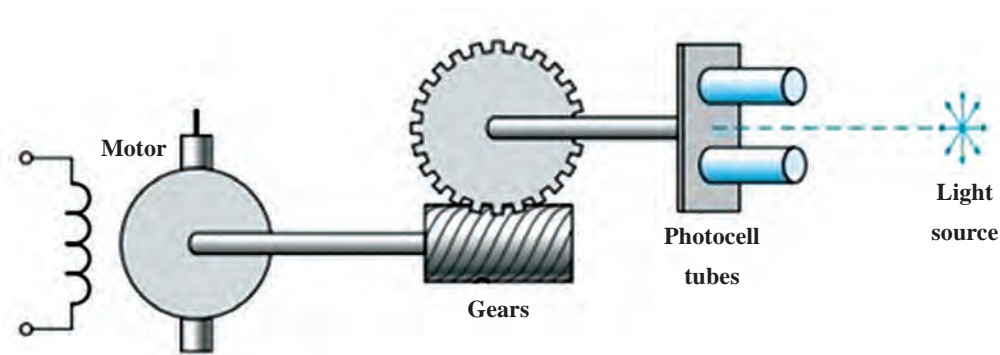

FIGURE 1.15 A photocell is mounted in each tube

Exercise:



Read the following text carefully

Try to design a control system for the process

In a chemical process control system, it is valuable to control the chemical composition of the product. To do so, a measurement of the composition can be obtained by using an infrared stream analyzer, as shown in Figure P1.16. The valve on the additive stream may be controlled. Complete the control feedback loop, and sketch a block diagram describing the operation of the control loop.

FIGURE P1.16
Chemical composition control.

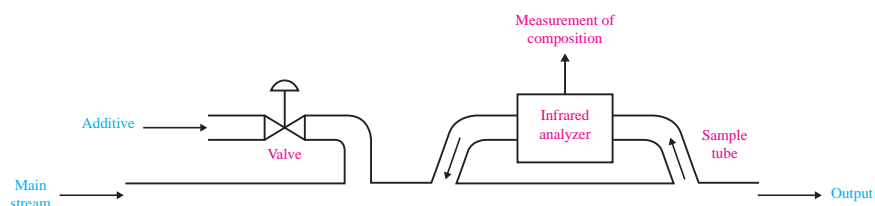

Element Modeling:

Comparison between electrical and mechanical systems:

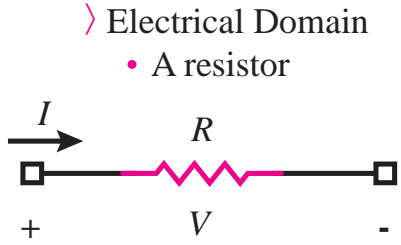

$$V = RI$$

Electrical Power = VI

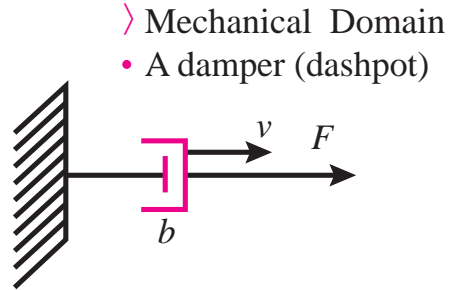

$$F = bv$$

Mechanical Power = Fv

$$R = b$$

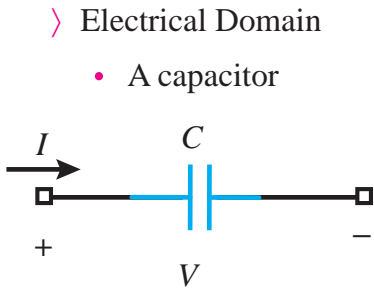

$$Q = CV$$

Electrical Power = VI

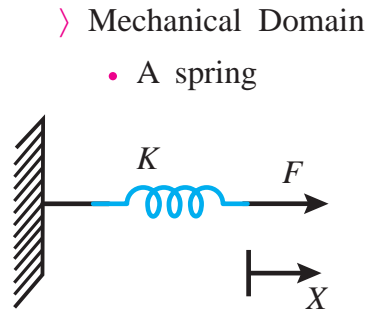

$$X = \frac{1}{K} F$$

Mechanical Power = Fv

$$C = \frac{1}{K}$$

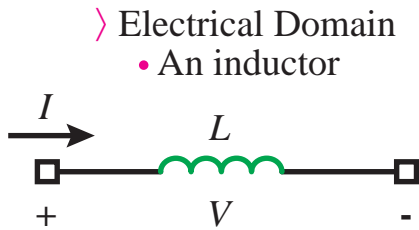

$$V = L \frac{dI}{dt}$$

Electrical Power = VI

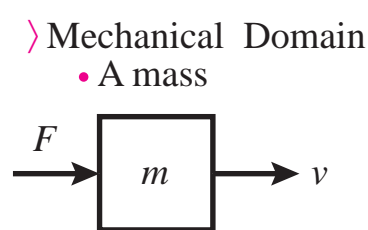

$$F = ma$$

Mechanical Power = Fv

$$L = m$$

Look carefully at the table below
 Try to understand between the main concepts
 Effort-flow relations occur in MANY different energy

General	Electrical	Mechanical	Fluidic	Thermal
Effort (e)	Voltage, V	Force, F	Pressure, P	Temp. diff., ΔT
Flow (f)	Current, I	Velocity, V	Vol. flow rate, Q	Heat flow
Displacement (q)	Charge, Q	Displacement, x	Volume, V	Heat, Q
Momentum (p)	-	Momentum, P	Pressure Δ , Momeunteum	-
Resistanc	Resistor, R	Damper, b	Fluidic resistance, R	Thermal resistance, R
capacitance	Capacitor, C	Spring, k	Fluid capacitance, C	Heat capacity, mcp
Inertance	Inductor, L	Mass, m	Inertance, M	-
Node law	KCL	Continuity of space	Mass conservation	Heat energy conservation
Mesh law	KVL	Newton's 2 nd law	Pressure is relative	Termperature is relative

Elements that share flow (e.g., current) and displacement (e.g., charge) are placed in series in an electric circuit. Elements that share a common effort (e.g., Voltage) are placed in parallel in an electric circuit.

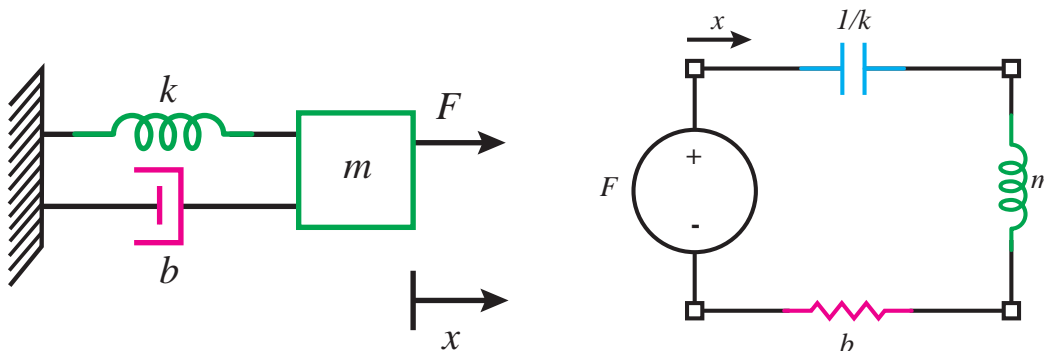

Spring-mass - dashpot system

Equivalent circuit

Generating equivalent circuits:

Easier to do via circuit duals:

Use convenience of $f \rightarrow V$ convention, then switch to $e \rightarrow V$

Force is current source.

Each displacement variable is a node.

Masses connected between nodes and ground.

Other elements connected as shown in diagram.

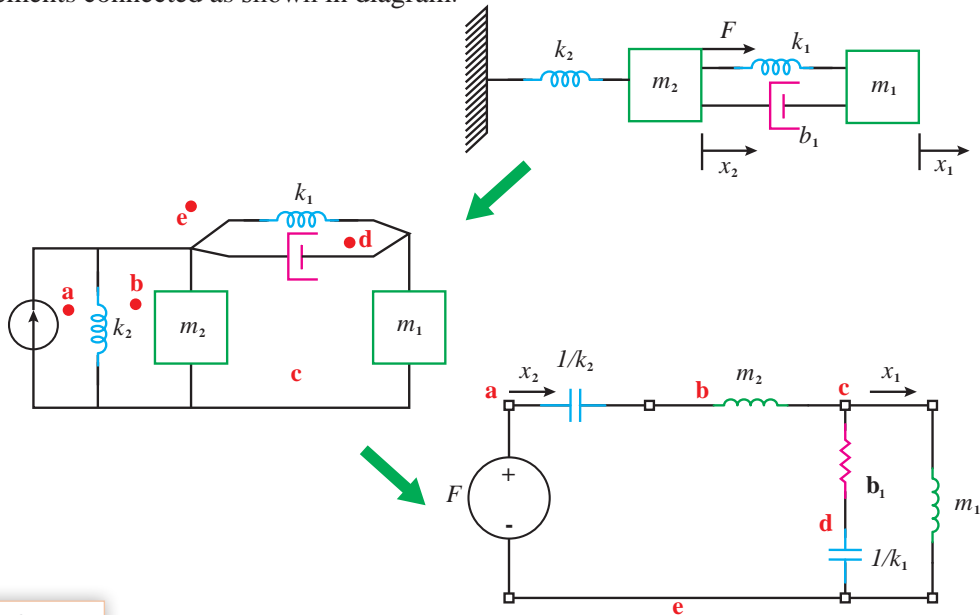

Exercise:

Finding equivalent circuit: direct approach

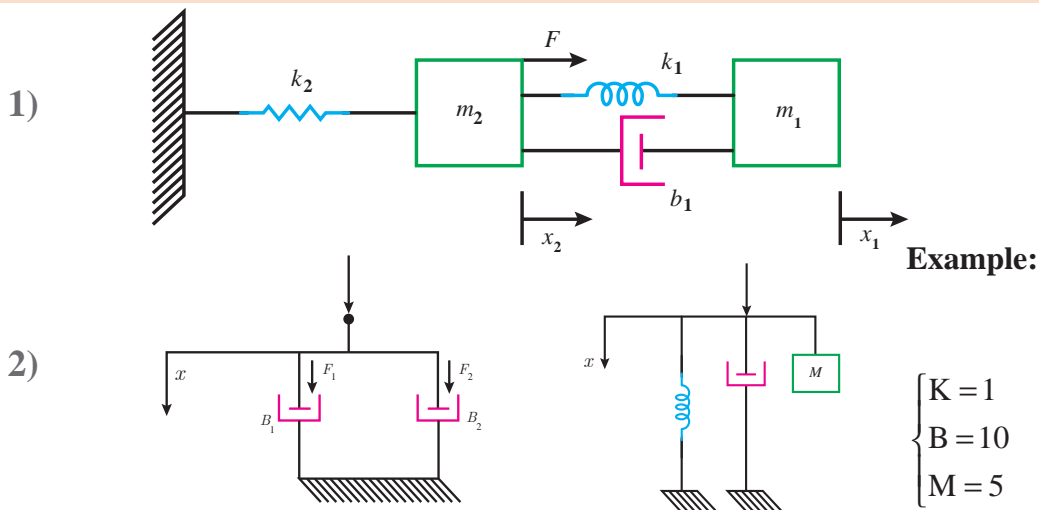

نمره	شاخص تحقق	نتایج مورد انتظار	استاندارد عملکرد (کیفیت)	تکالیف عملکردی (واحدهای یادگیری)	عنوان پودمان
۳	تعریف رشته مکترونیک و کاربرد این رشته در صنایع مختلف، تعیین مشخصات سیستم های مکترونیکی (کواد کوپتر، ترمز ضد قفل، بازوی بیو مکترونیکی، قطارهای مغناطیسی) تعیین انواع سیستم ارتینگ و لزوم استفاده از آنها، تعیین مشخصات الکتریکی موتور از روی پلاک، تعیین مشخصات فنی آی سی از دیتاشیت، تبدیل یک سیستم کنترل حلقه باز به حلقه بسته، تعیین مراحل طراحی یک سیستم کنترلی، معادل سازی یک سیستم الکتریکی به سیستم مکانیکی	بالا تر از حد انتظار	بررسی و ترجمه متون تخصصی رشته مکترونیک و کسب اطلاعات فنی مورد نیاز از آنها و تحلیل سیستم های کنترلی	۱- ترجمه متون تخصصی و استخراج اطلاعات فنی مورد نیاز از آنها	پودمان ۱: کسب اطلاعات فنی
۲	تعریف رشته مکترونیک و کاربرد این رشته در صنایع مختلف، تعیین مشخصات سیستم های مکترونیکی (کواد کوپتر، ترمز ضد قفل، بازوی بیو مکترونیکی، قطارهای مغناطیسی) تعیین انواع سیستم ارتینگ و لزوم استفاده از آنها، تعیین مشخصات الکتریکی موتور از روی پلاک، تعیین مشخصات فنی آی سی از دیتاشیت	در حد انتظار	مکترونیک و کسب اطلاعات فنی مورد نیاز از آنها و تحلیل سیستم های کنترلی	۲- تحلیل سیستم های با ساختار و هویت مکترونیکی و شبیه سازی و بهبود سیستم های کنترلی	
۱	تعریف رشته مکترونیک و کاربرد این رشته در صنایع مختلف، تعیین مشخصات سیستم های مکترونیکی (کواد کوپتر، ترمز ضد قفل، بازوی بیو مکترونیکی، قطارهای مغناطیسی)	پایین تر از حد انتظار			
				نمره مستمر از ۵	
				نمره شایستگی پودمان	
				نمره پودمان از ۲۰	